

Representation learning: A new approach for biomedical data

Marinka Zitnik (marinka@cs.stanford.edu)

Stanford | ENGINEERING
Computer Science



Stanford
MEDICINE



CHAN ZUCKERBERG
BIOHUB



Science crucially depends on scientific instruments

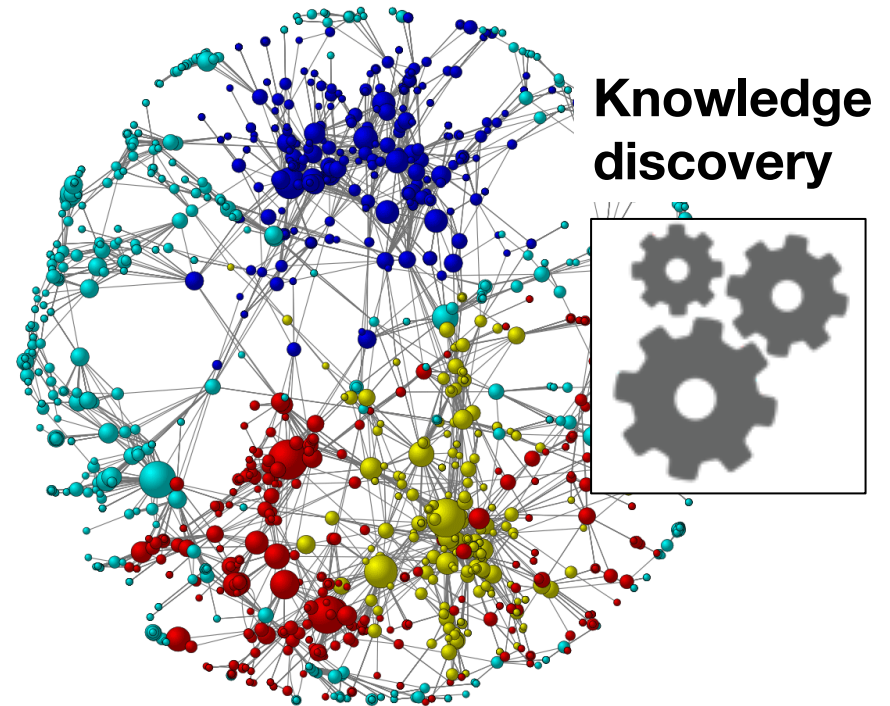
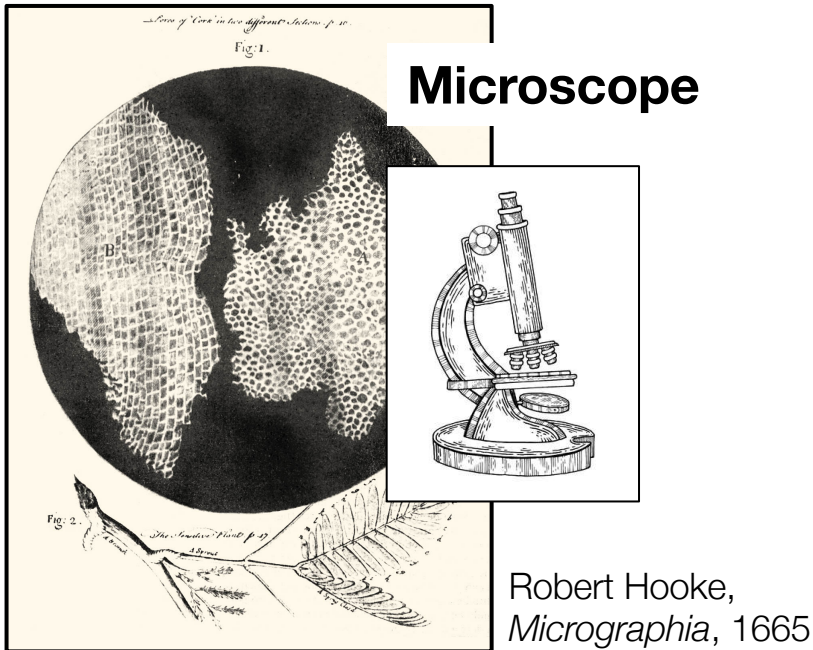

Physical instruments facilitate discoveries

Need instruments for modern, data-intensive sciences

Knowledge Discovery

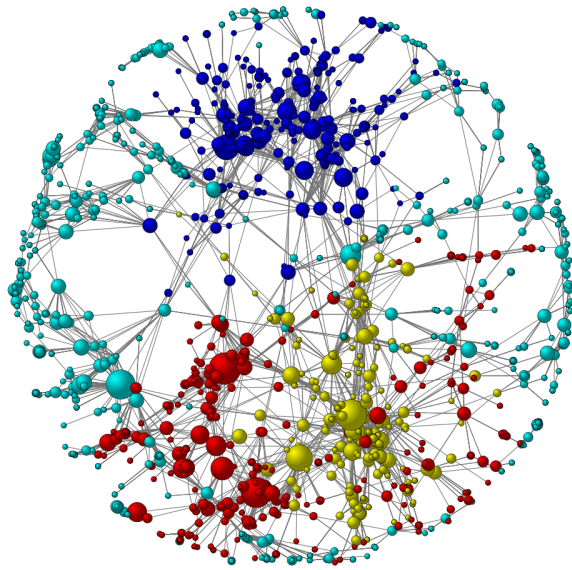

Data



Data + ML/AI



Predictions
and insights

Opportunities for AI in health & medicine



**Preliminary diagnosis,
early disease
detection, self-care**



**Automated image
diagnosis,
language modeling**



**Clinical trial participation,
drug discovery, AI-driven
medical devices**



**Comorbidities,
chronic disease
treatments**



**Improve administrative
workflows, costly
back-office problems**



**Inpatient & outpatient
policies of care**



**Real-time patient
interventions**



**Help protect health
data, avoid medical
errors**

Why is it so challenging to realize this vision?

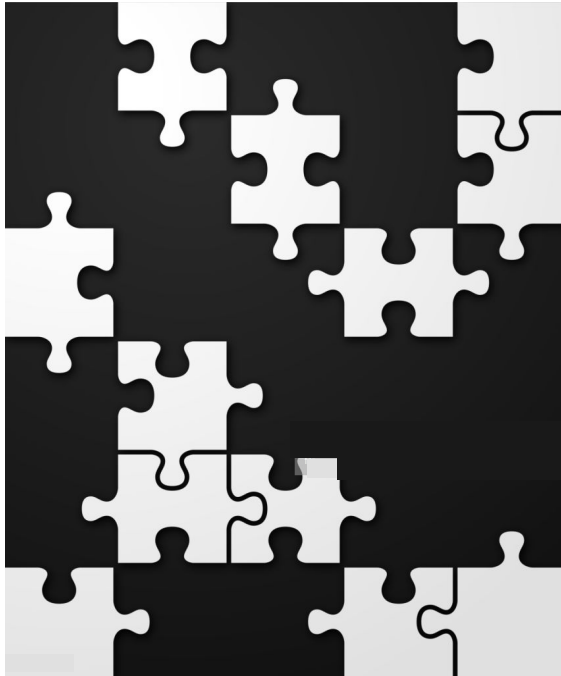

Multi-scale: molecules, individuals, populations

Heterogeneous: experimental readouts, curated annotations, self-reported

Confounded: data from different labs, hospitals, biotech platforms, species

Networks allow for integration of biomedical data

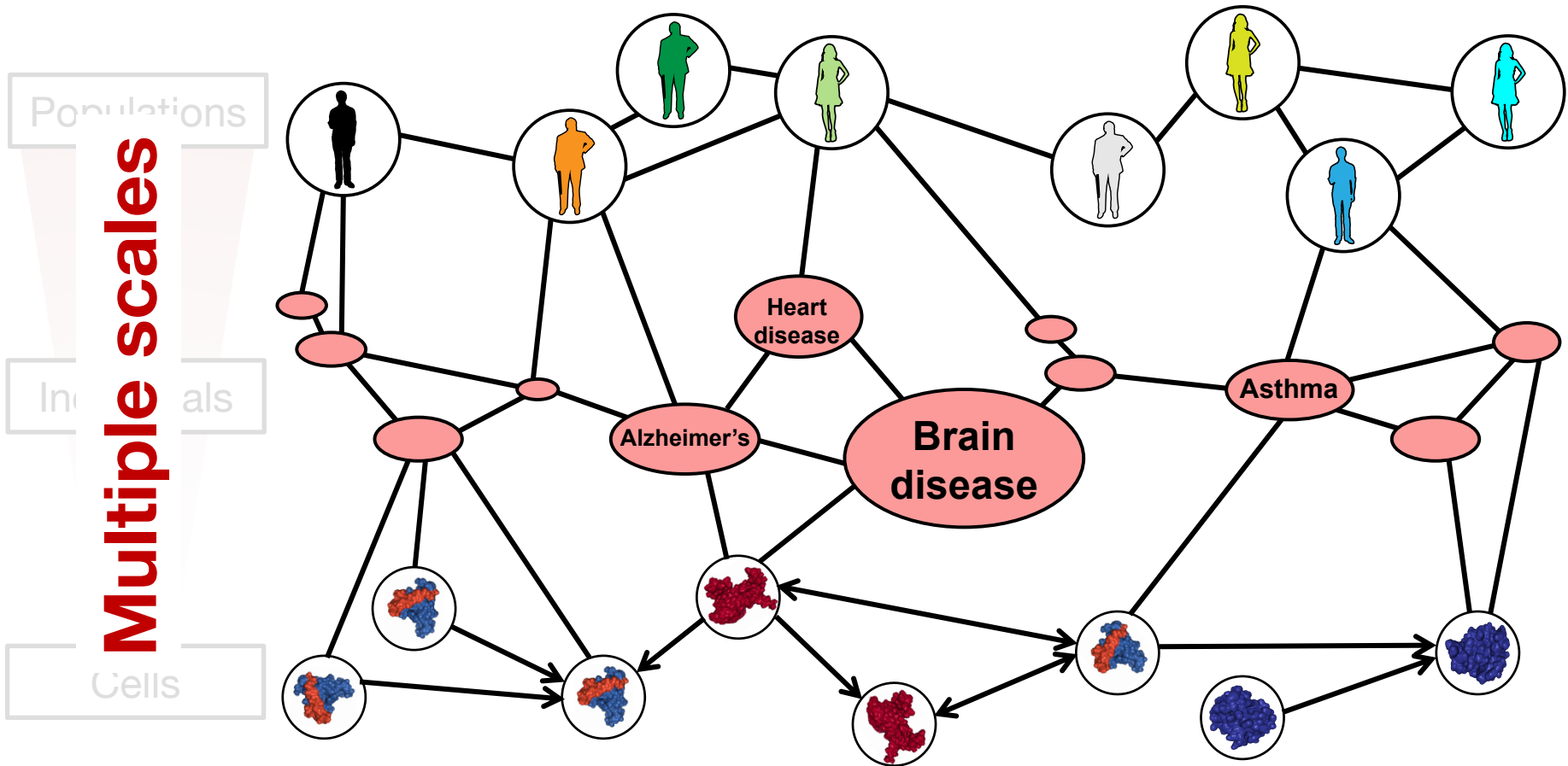

Rich, multimodal data

Many biomedical data are networks

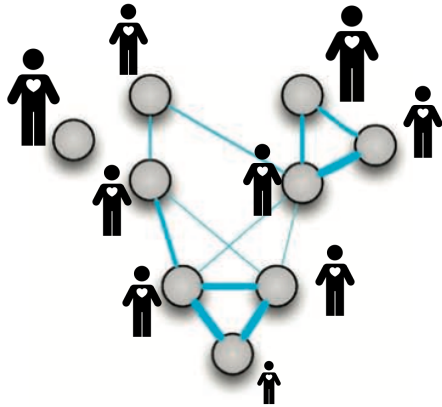

Patient networks

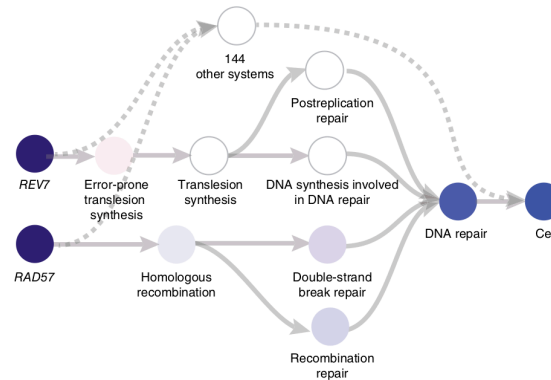

Hierarchies of cell systems

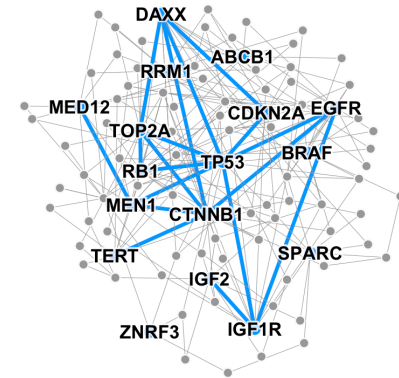

Disease pathways

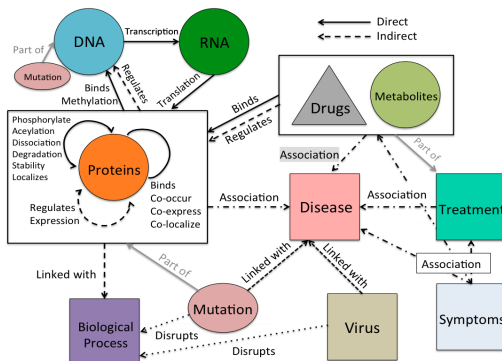

Biomedical knowledge graphs

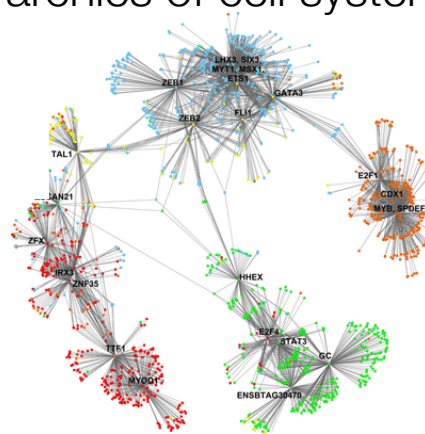

Gene interaction networks

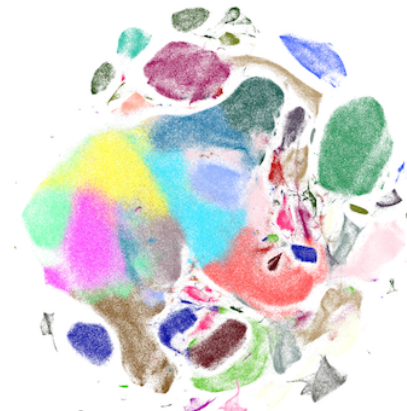

Cell-cell similarity networks

Prioritizing Network Communities, *Nature Communications* 2018

Network Enhancement as a General Method to Denoise Weighted Biological Networks, *Nature Communications* 2018

Evolution of resilience in protein interactomes across the tree of life, *PNAS* 2019

How to do machine learning on biomedical networks?

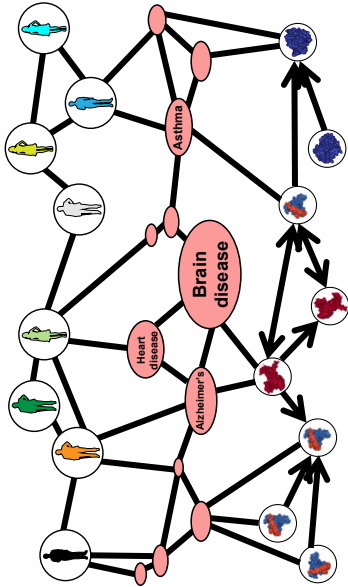

Networks

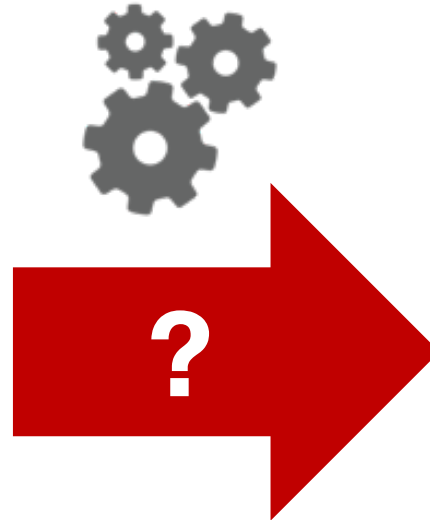

Predictions
and insights

Biomedical ML opens new avenues for:

- Understanding nature, analyzing health, and developing medicines
- How predictive modeling is performed today at the fundamental level

Today's Talk

 **1. Representation learning** for biomedical data

2. Three research applications:

- Used new approach to predict **safety** and **side effects of drug combinations**
- Used new approach to **repurpose old drugs for new diseases**
- Used new approach to **answer logical queries** on **knowledge graphs**

How to learn deep models on biomedical networks?

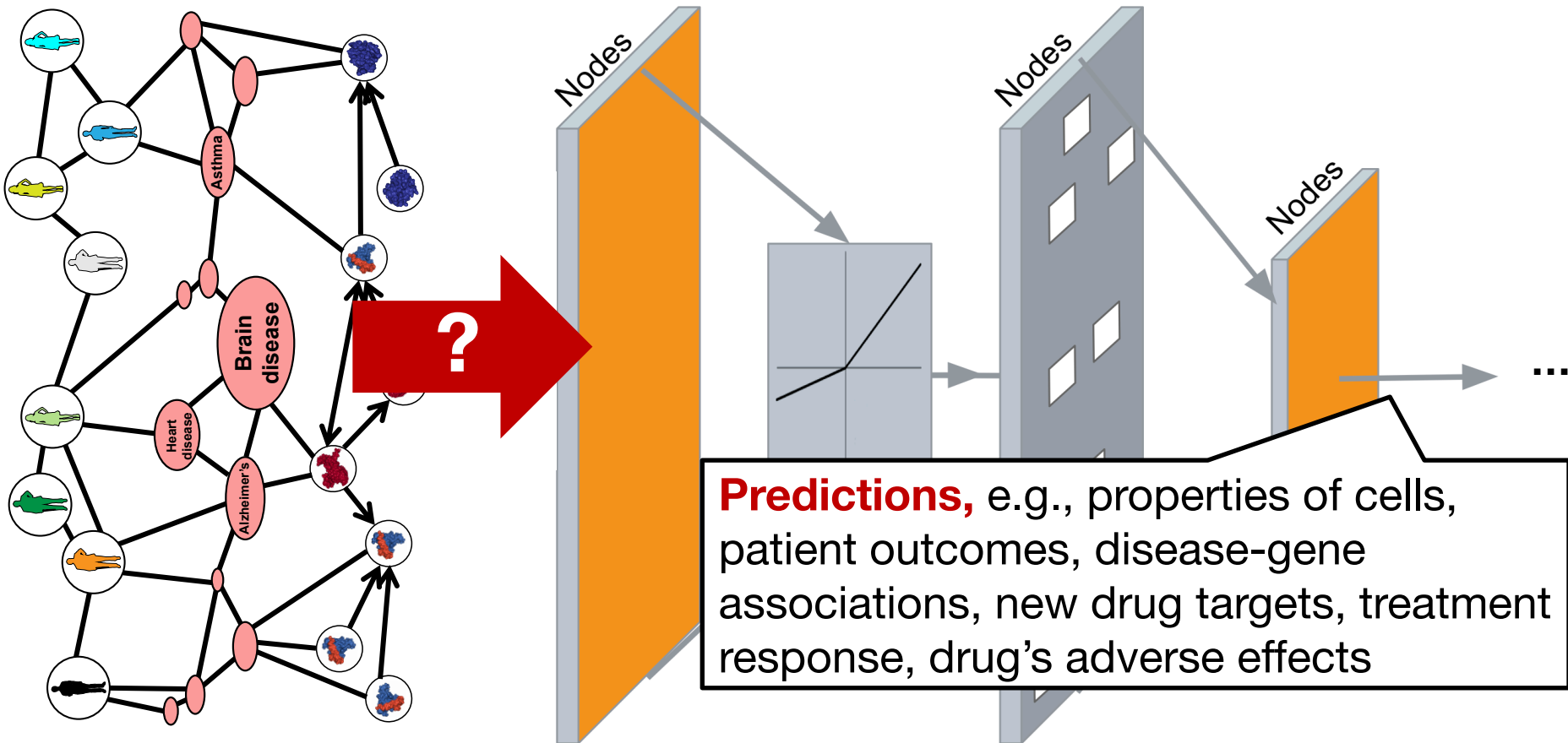

Networks are a powerful data representation, but are challenging to work with for prevailing ML

Prevailing Deep Models

Primarily designed for **grids** or **simple sequences**:

- CNNs for fixed-size images/grids

These models brought extraordinary gains in **computer vision, natural language processing, speech, and robotics**

■ RNNs for text/sequences...

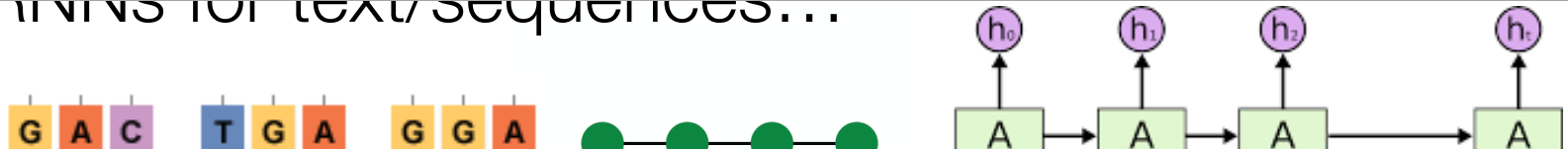

But are **unable to consider interactions**, the essence of networks

Why is deep learning on networks hard?

Biomedical networks are far more complex!

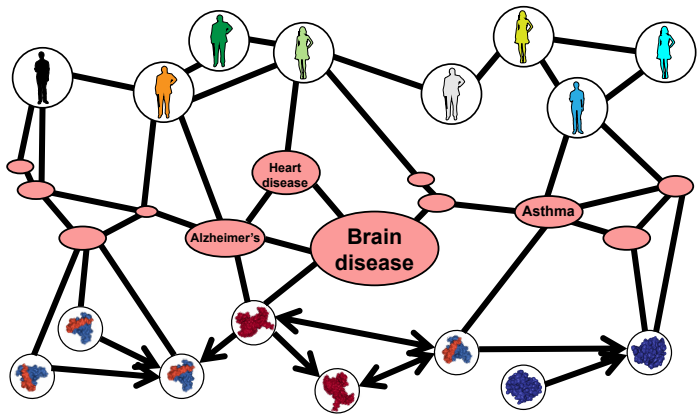

Biomedical networks

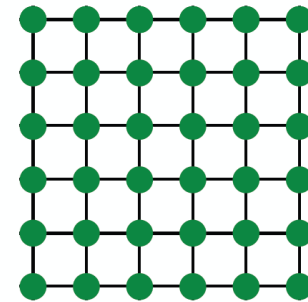

Images



Text

Examples:

Human contact networks, Disease networks, Patient networks, Cell similarity networks, Medical knowledge graphs

A Naïve Approach

- Join adjacency matrix and features
- Feed them into a deep neural model:

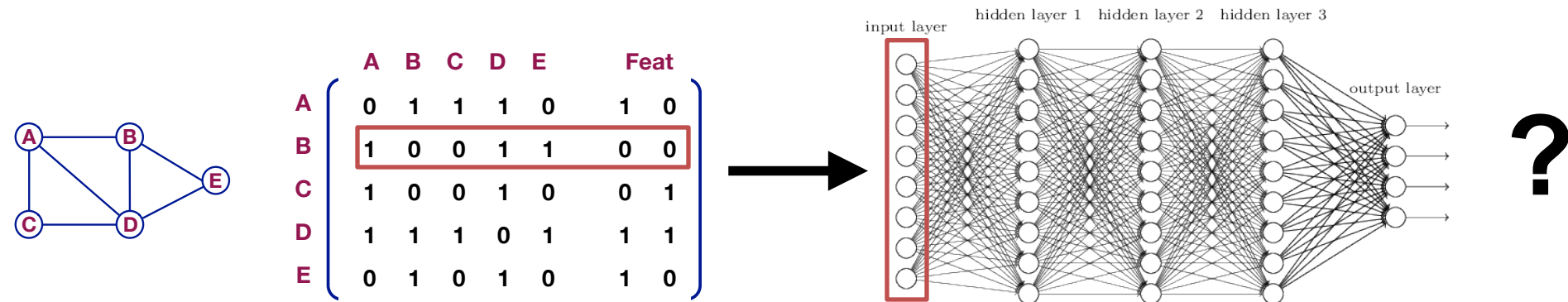

- Issues with this idea:
 - $O(N)$ parameters
 - Not applicable to graphs of different sizes
 - Not invariant to node ordering

Today's goal: Deep learning for biomedical networks

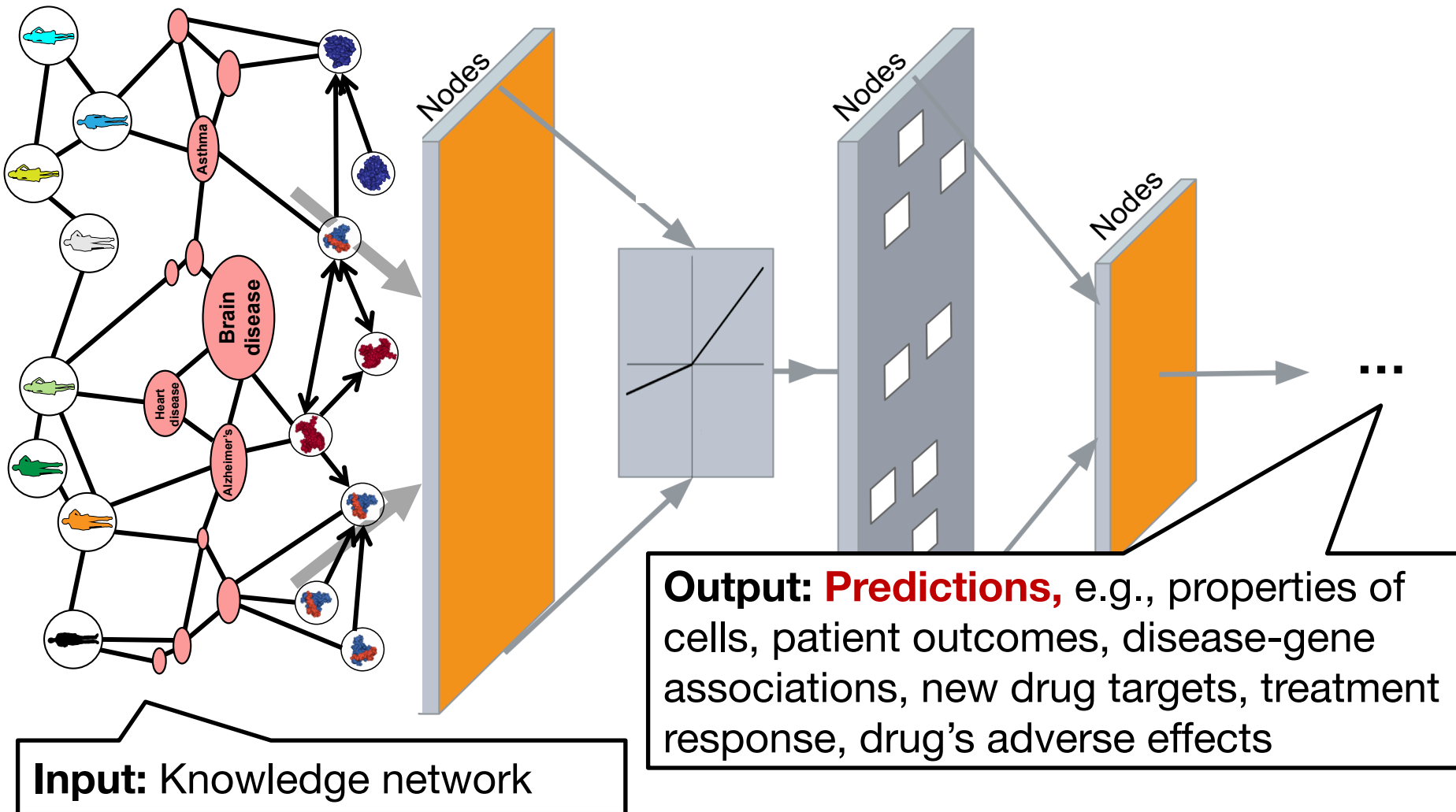

Setup: A Multimodal Network

r_i Edge type i
● ▲ Node types

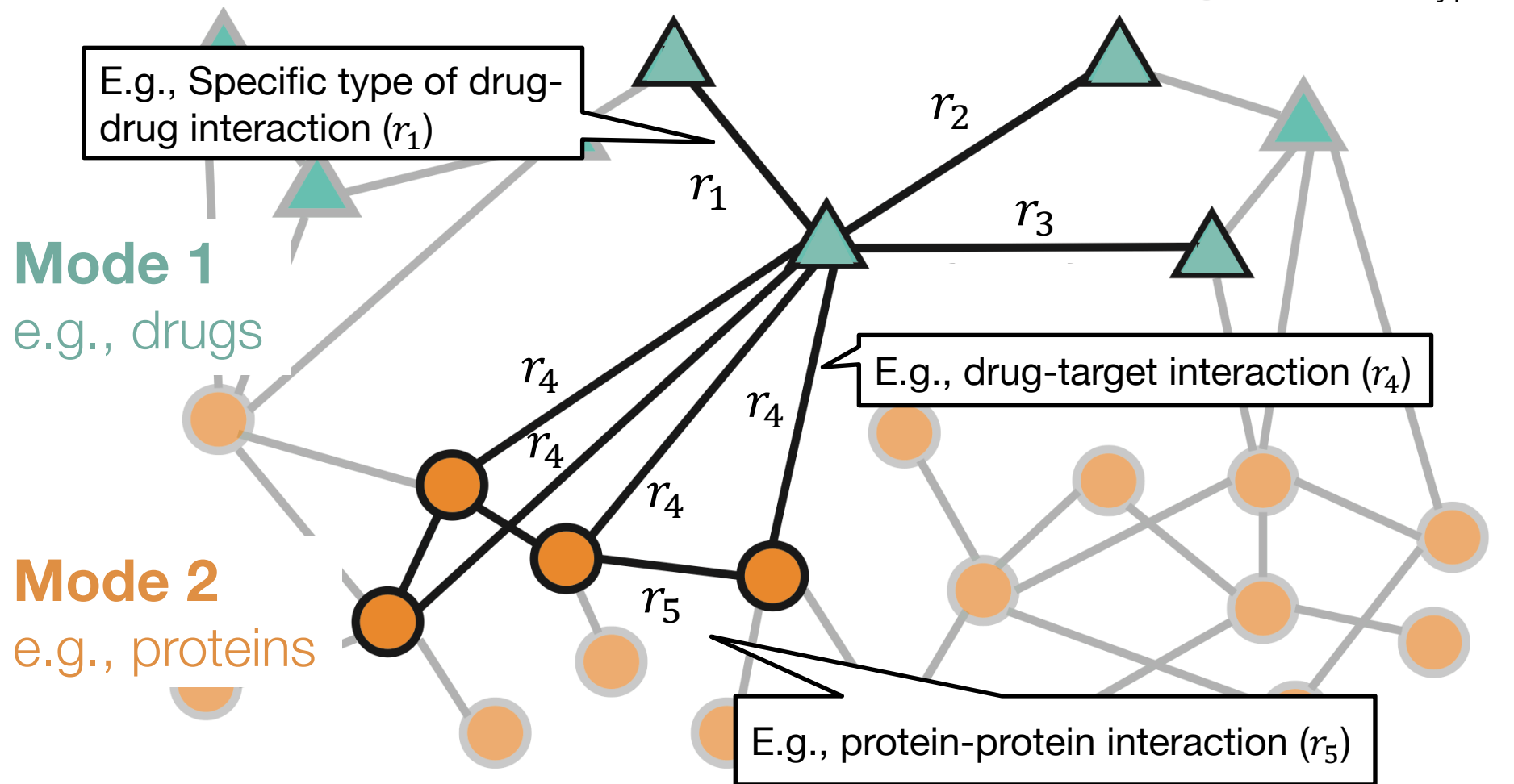

Overview of our deep learning approach for networks

1. Encoder: Take a multimodal network and learn an *embedding* for every node



2. Decoder: Use the learned embeddings to predict labeled edges between nodes

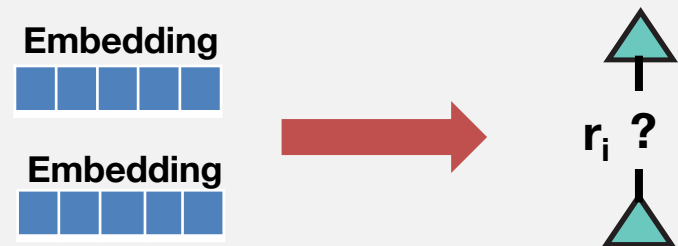

Embedding Nodes

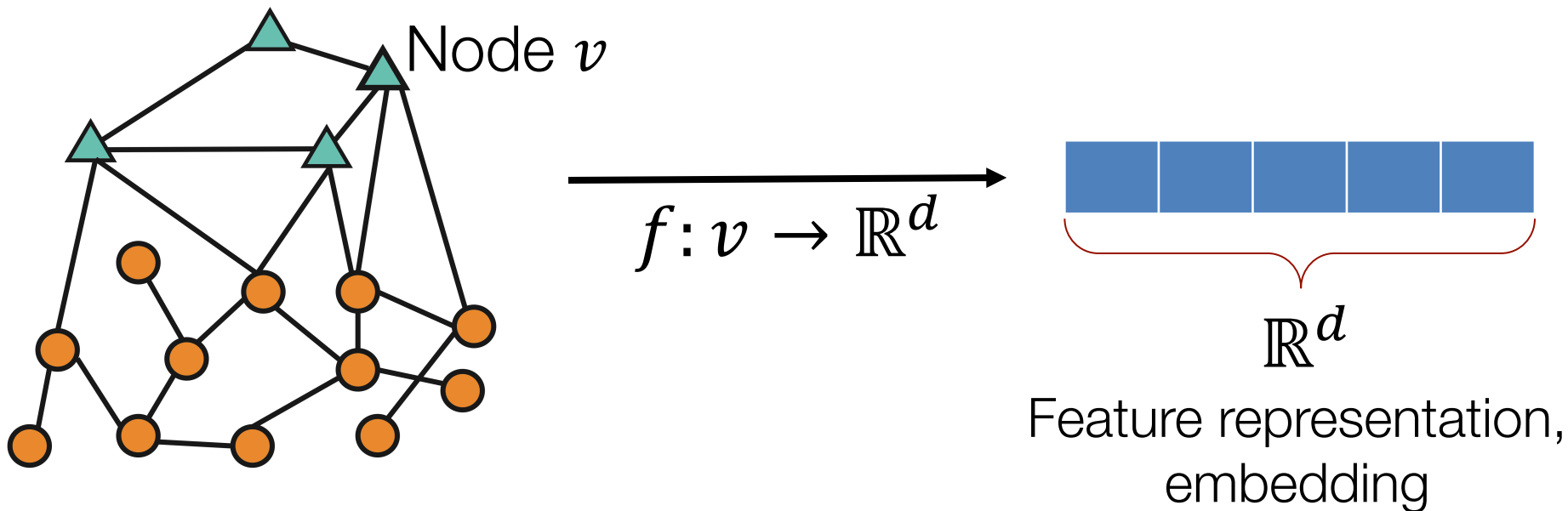

Objective: Map nodes to d -dimensional embeddings such that **nodes with similar network neighborhoods** are embedded close together

Next: How to learn mapping function f ?

Embedding Nodes

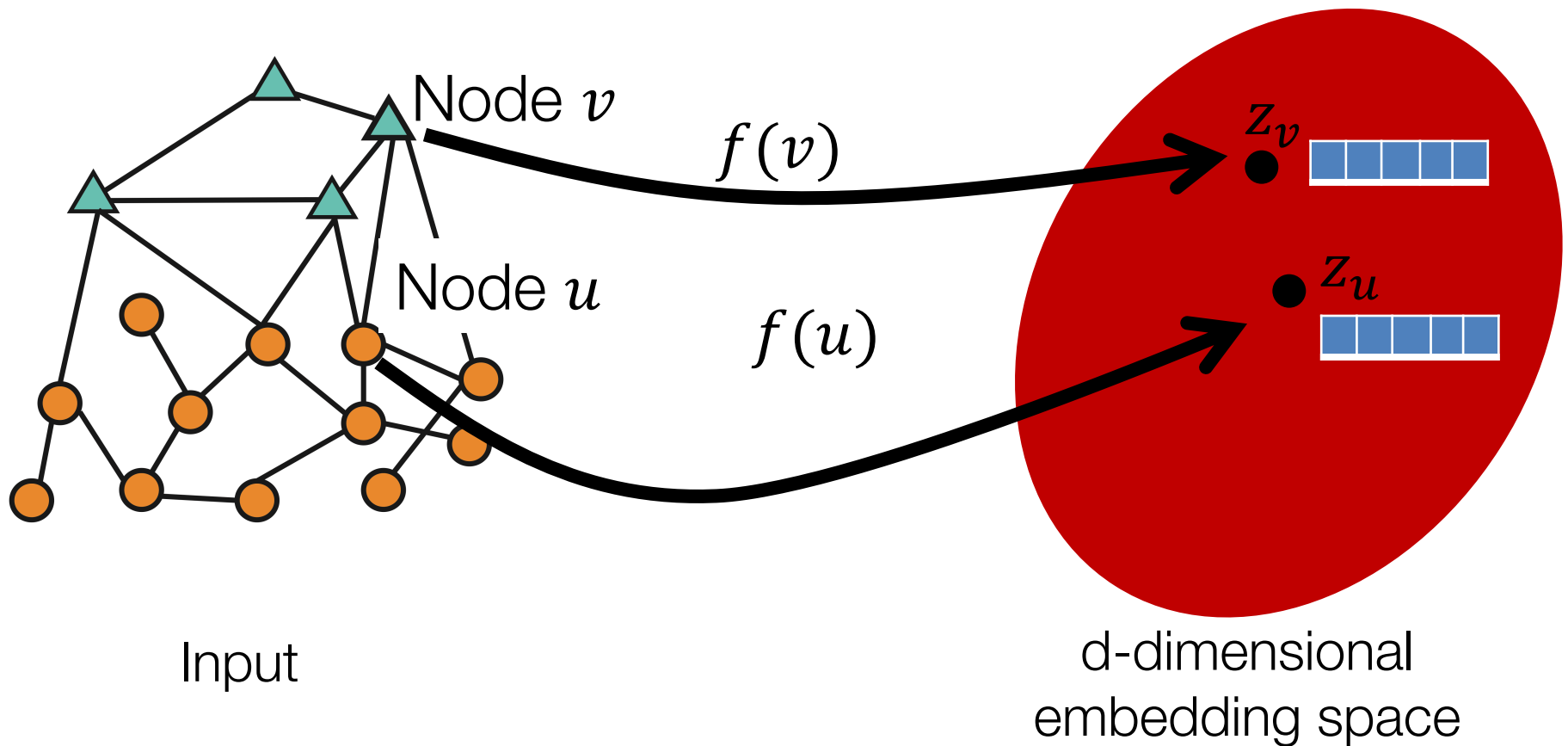

Goal: Map nodes to d-dimensional embeddings such that nodes with similar network neighborhoods are embedded close together

Key Idea: Aggregate Neighbors

Generate embeddings based on **local network neighborhoods separated by edge type**

1) Determine a node's computation graph for each edge type

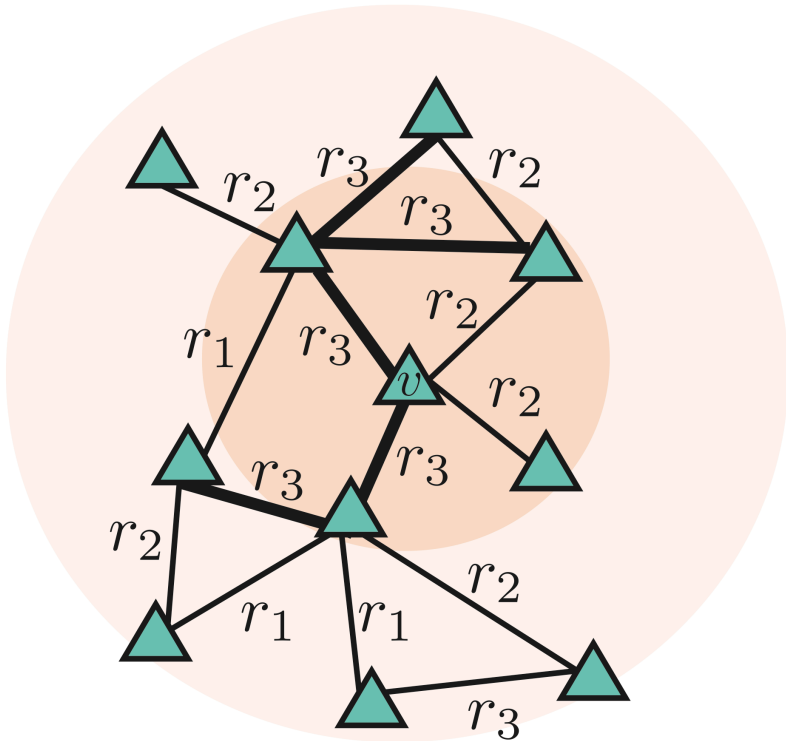

2) Learn how to transform and propagate information across computation graph

Example for edge type r_3 :

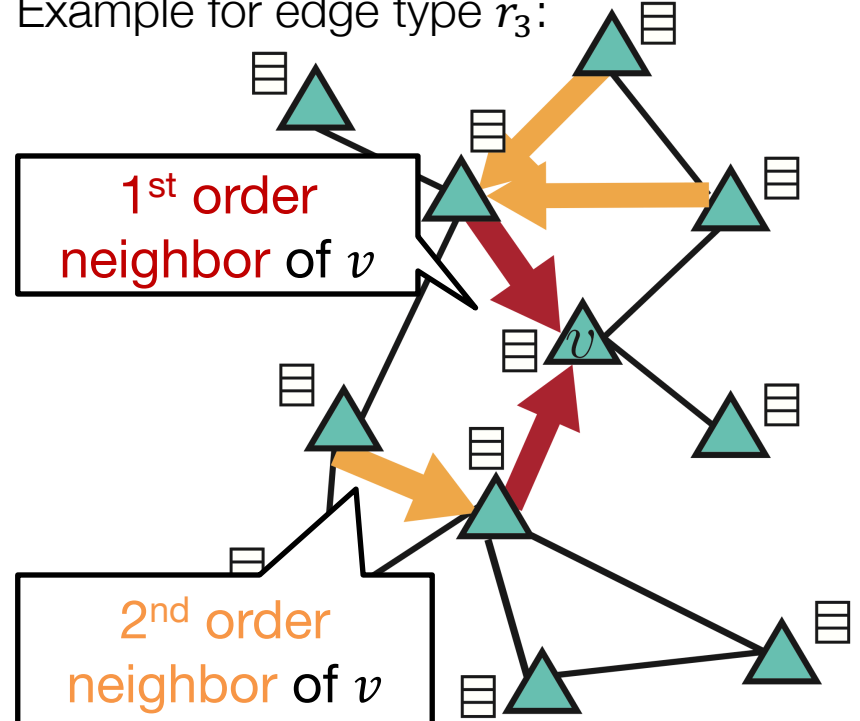

Example: Aggregate Neighbors

1st order network neighborhood of node C

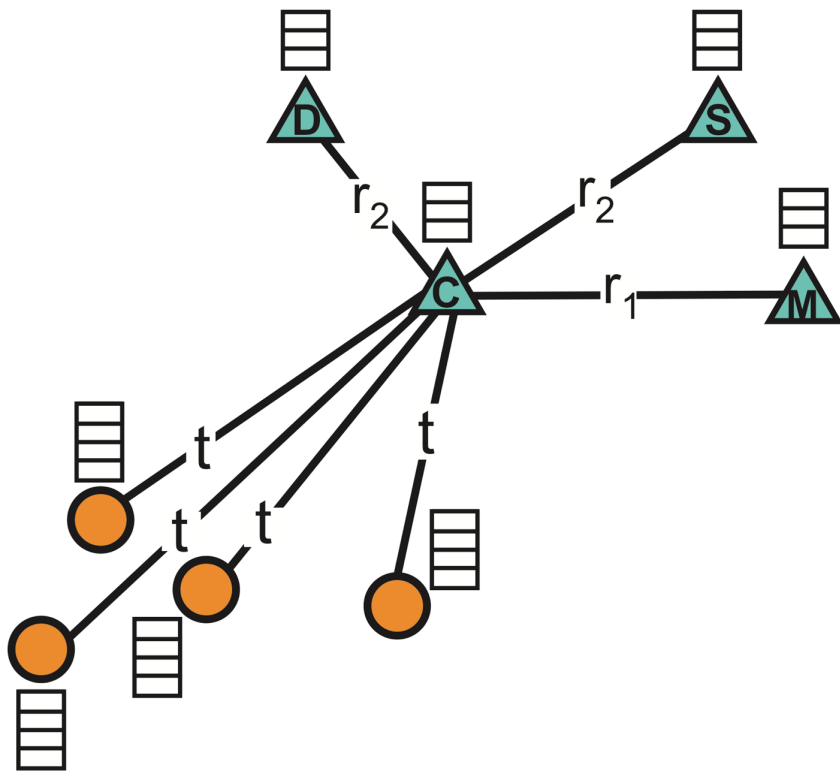

1st order computation graph of node C

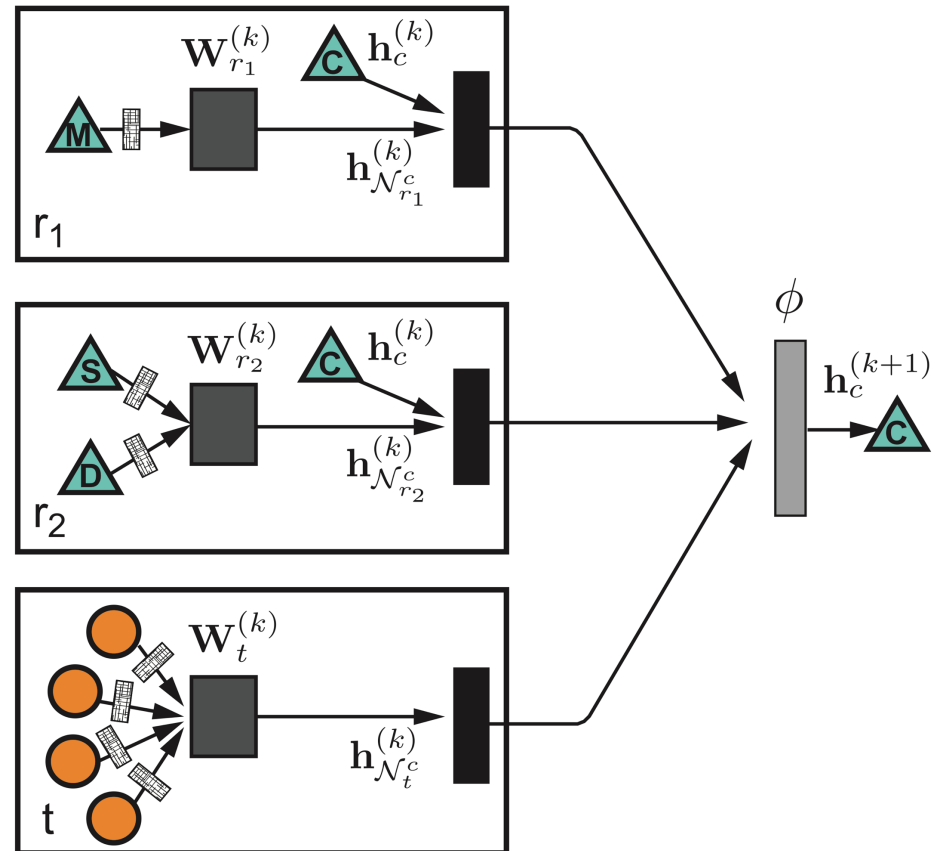

Every node learns how to aggregate its own neighbors

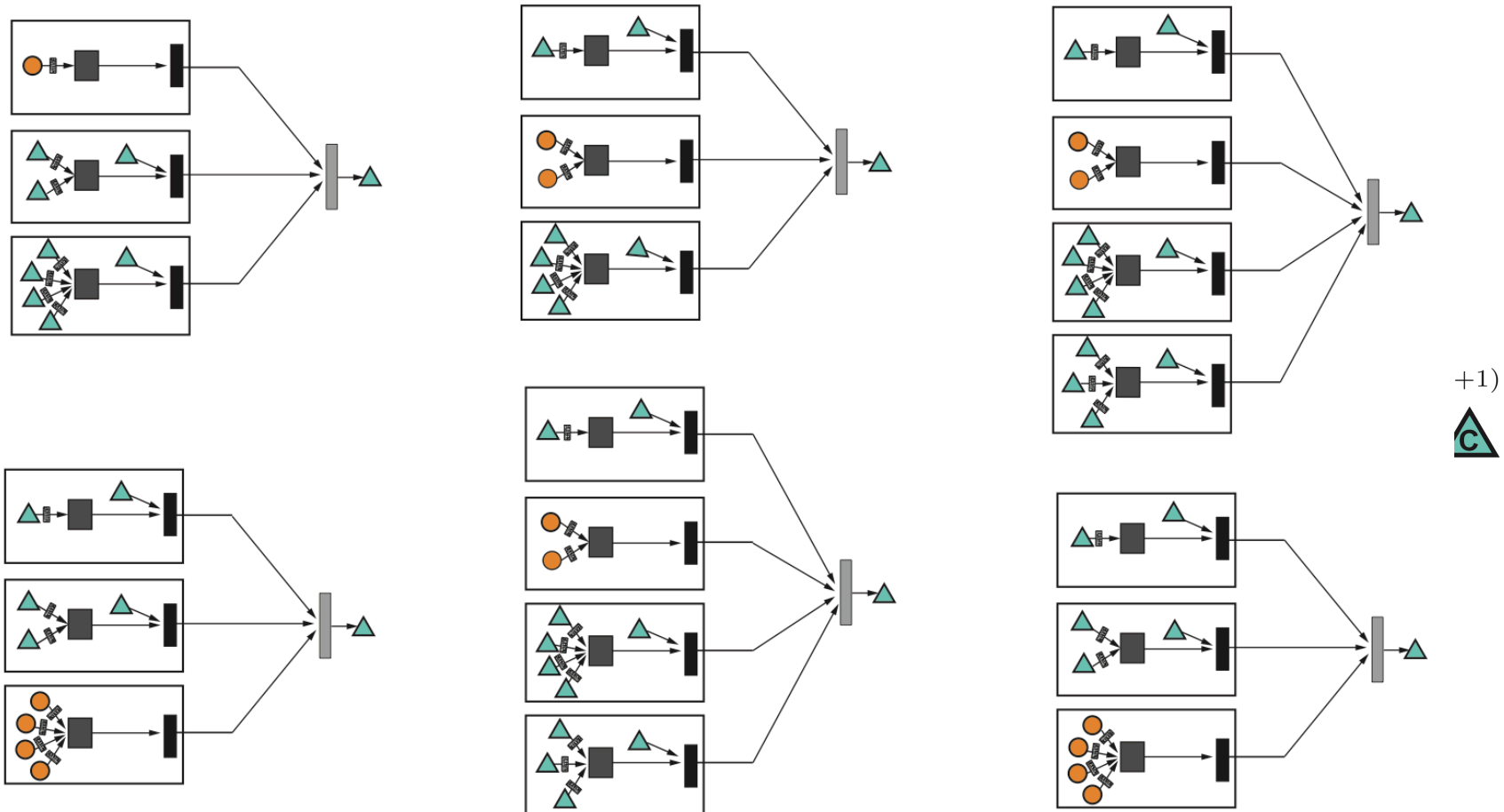

Every node defines a unique computation graph

Deep Model: Many Layers

Layer-0

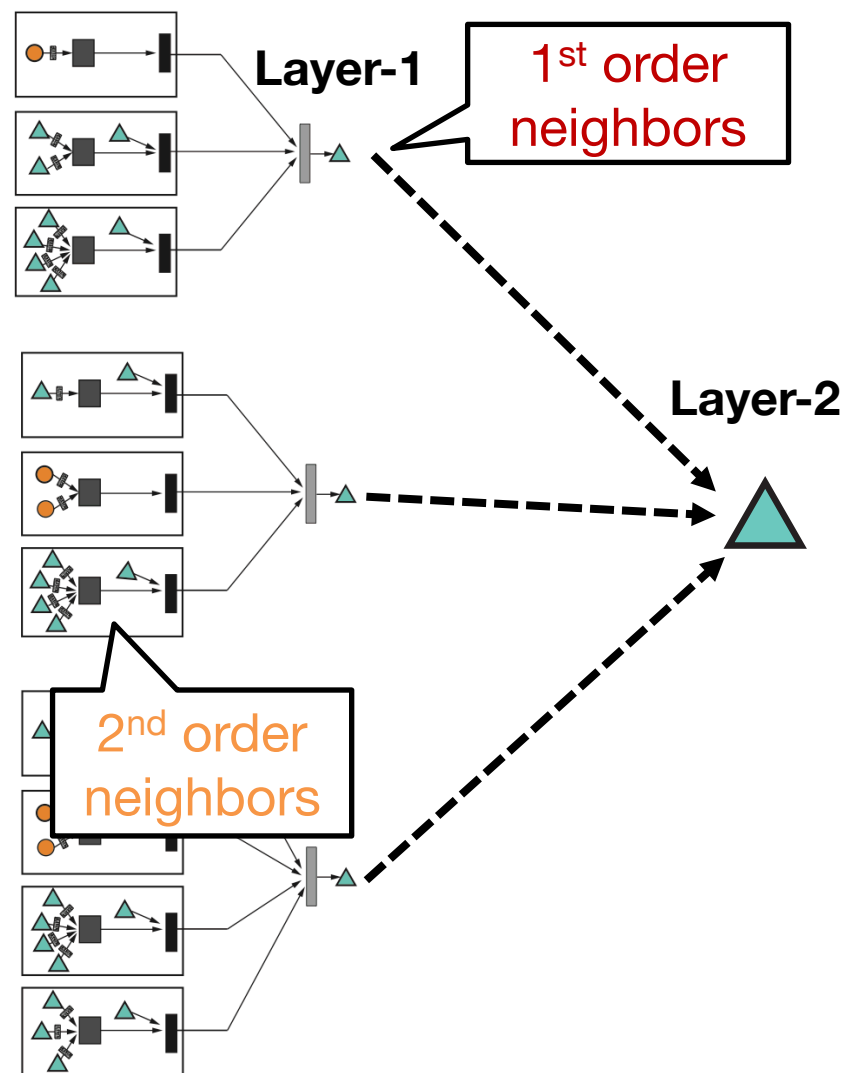

Model can be of arbitrary depth:

- Nodes have embeddings at each layer
- Layer-0 embeddings are nodes' input features

Deep model with K layers:

- Convolves information across K^{th} order neighborhood
- Embedding of a node depends on nodes at most K hops away

Recap: Nodes with **similar network neighborhoods** are embedded **close together**

The Math: Deep Graph Encoder

Key element: Each node's computation graph defines a neural network with a different architecture

- Initial 0-th layer embeddings are equal to node features:

$$\mathbf{h}_v^{(0)} = \mathbf{x}_v$$

Aggregate neighbor's previous-layer embeddings, separated by edge type

Ability to integrate side information about nodes

- Per-layer update of node embeddings:

$$\mathbf{h}_v^{(k)} = \phi \left(\sum_r \sum_{u \in N_v^r} c_r^{uv} \mathbf{W}_r^{(k-1)} \mathbf{h}_u^{(k-1)} + c_r^v \mathbf{h}_v^{(k-1)} \right) \quad k = 1, \dots, K$$

Previous-layer embedding of v

- Embeddings after K layers of neighborhood aggregation:

$$\mathbf{z}_v = \mathbf{h}_v^{(K)}$$

Normalization constant, fixed e.g., $1/|N_v^r|$, or learned

$\mathbf{W}_r^{(k)}$ Part

Overview of our deep learning approach for multimodal networks

✓ **1. Encoder:** Take a multimodal network and learn an *embedding* for every node



✎ **2. Decoder:** Use the learned embeddings and *make predictions*

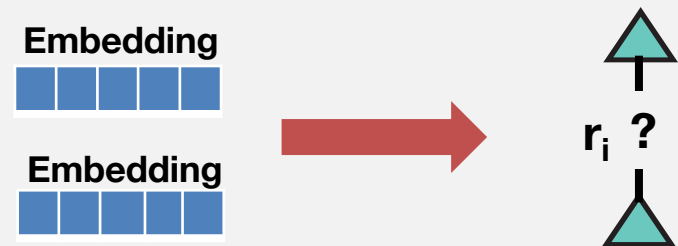

What Can We Predict?

- **Node prediction:** E.g., Predicting protein functions across tissues
- **Pairs of nodes:** E.g., Predicting side-effects and safety of drug combinations
- **Subgraph prediction:** E.g., Predicting what drug treats what disease
- **Graph prediction:** E.g., Predicting properties of molecules

We can now apply deep learning much more broadly, not only to medical images and biological, DNA sequences

New frontiers for applications in **biology** and **medicine**

Overview of our deep learning approach for multimodal networks

✓ **1. Encoder:** Take a multimodal network and learn an *embedding* for every node



✓ **2. Decoder:** Use the learned embeddings and *make predictions*

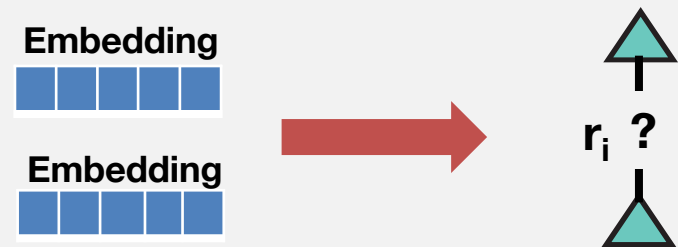

Training the model: Feed embeddings into any loss function and run stochastic gradient descent to train weight parameters:

- Use a loss based on e.g., random walks, node proximity in the graph
- Directly train the model for a supervised task (e.g., node classification)

Today's Talk



1. **Representation learning** for biomedical data

2. Three research applications:

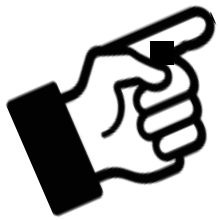

Used new approach to predict **safety** and **side effects of drug combinations**

- Used new approach to **repurpose old drugs for new diseases**

- Used new approach to **answer logical queries** on **knowledge graphs**

Polypharmacy

Patients **take multiple drugs** to treat **complex or co-existing diseases**

46% of people over 65 years take more than 5 drugs

Many take more than **20** drugs to treat heart diseases, depression or cancer

15% of the U.S. population affected by unwanted side effects

Annual costs in treating side effects exceed **\$177** billion in the U.S. alone

Unexpected Drug Interactions

Co-prescribed drugs

Side Effects

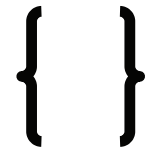
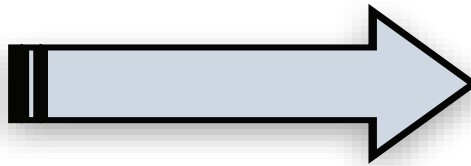

Task: How likely will a particular combination of drugs lead to a particular side effect?

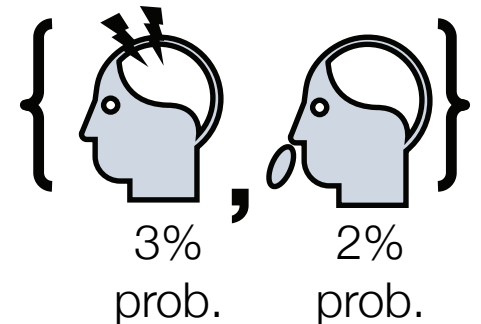
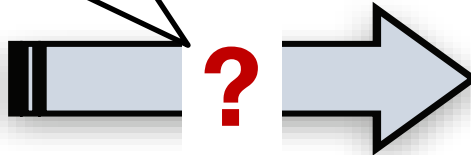
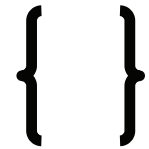
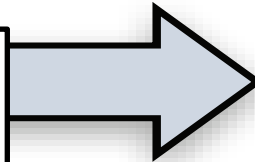

Why is modeling polypharmacy hard?

Combinatorial explosion

- >13 million possible combinations of 2 drugs
- >20 billion possible combinations of 3 drugs

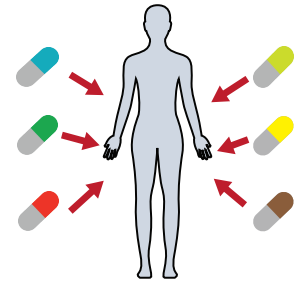

Non-linear & non-additive interactions

- Different effect than the additive effect of individual drugs



Small subsets of patients

- Side effects are interdependent
- No info on drug combinations not yet used in patients

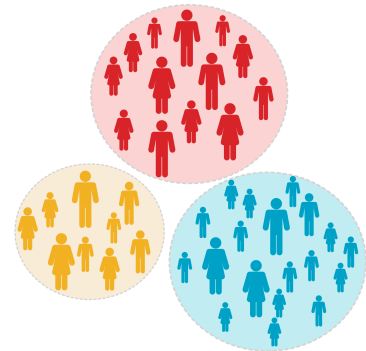

We need polypharmacy dataset

Objective
all drugs

We built

- 4,6
- eve
- 18,
- 719
- cou
- Dr
- pro

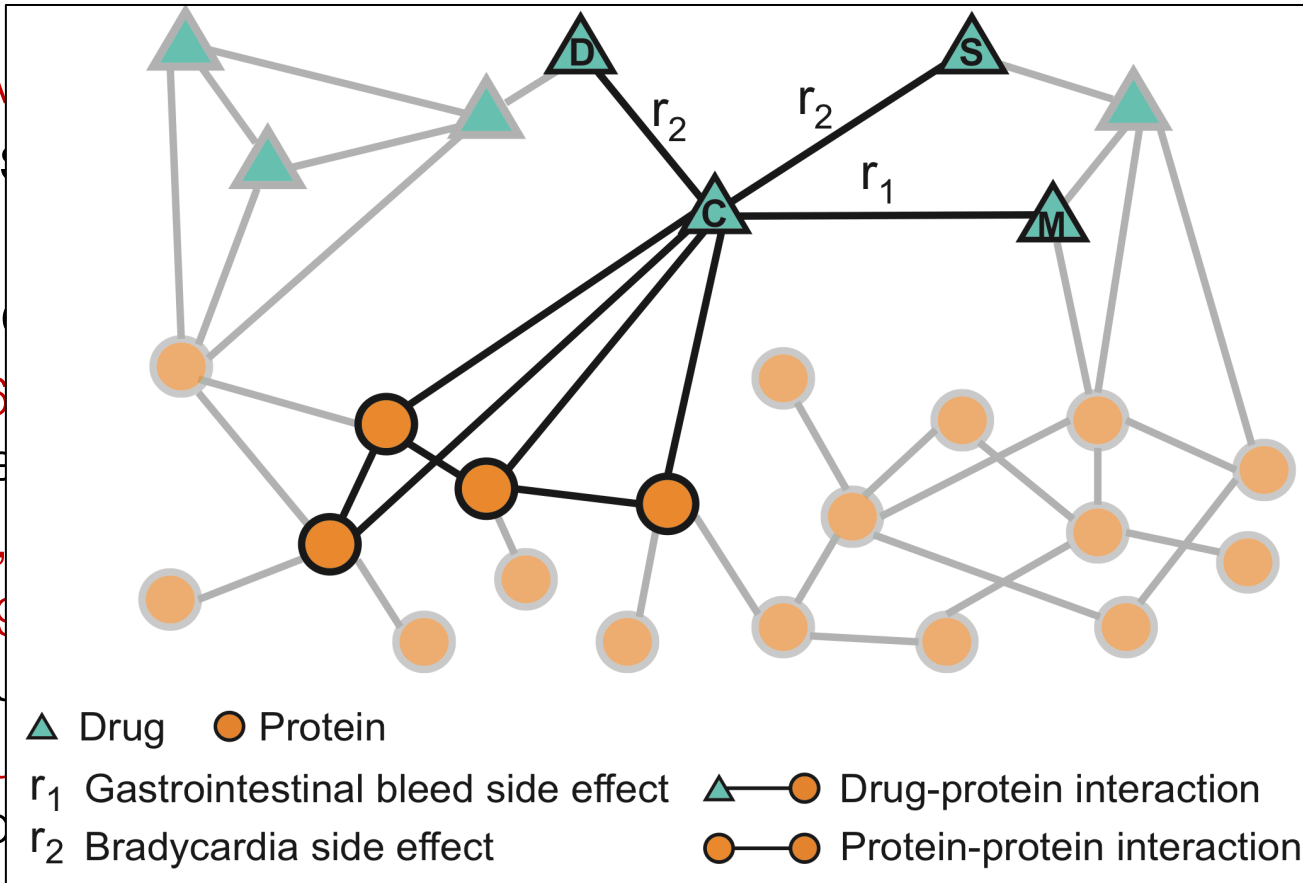

Drug-drug

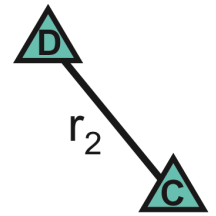

Drug-protein



Protein-protein



A polypharmacy network with over 5 million edges and over 1,000 different edge types

We apply our deep approach to the polypharmacy network

E.g.: How likely will Simvastatin and Ciprofloxacin, when taken together, break down muscle tissue?

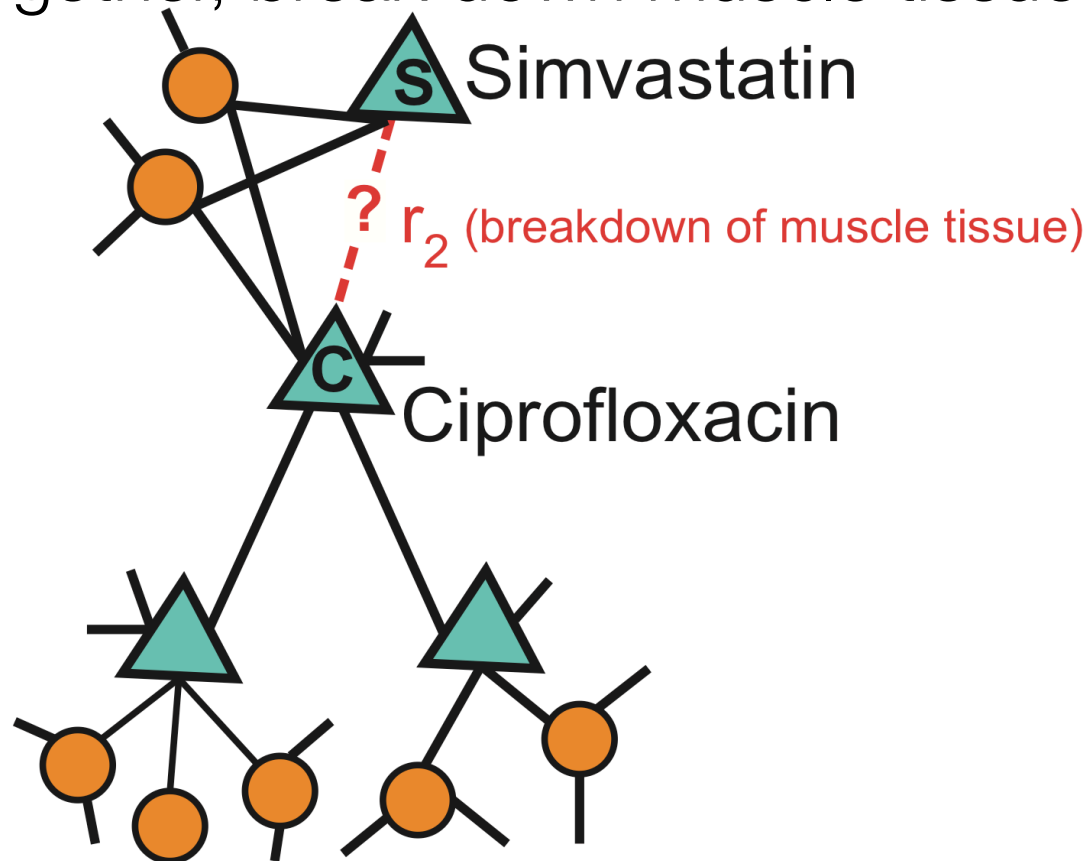

Results: Side Effect Prediction

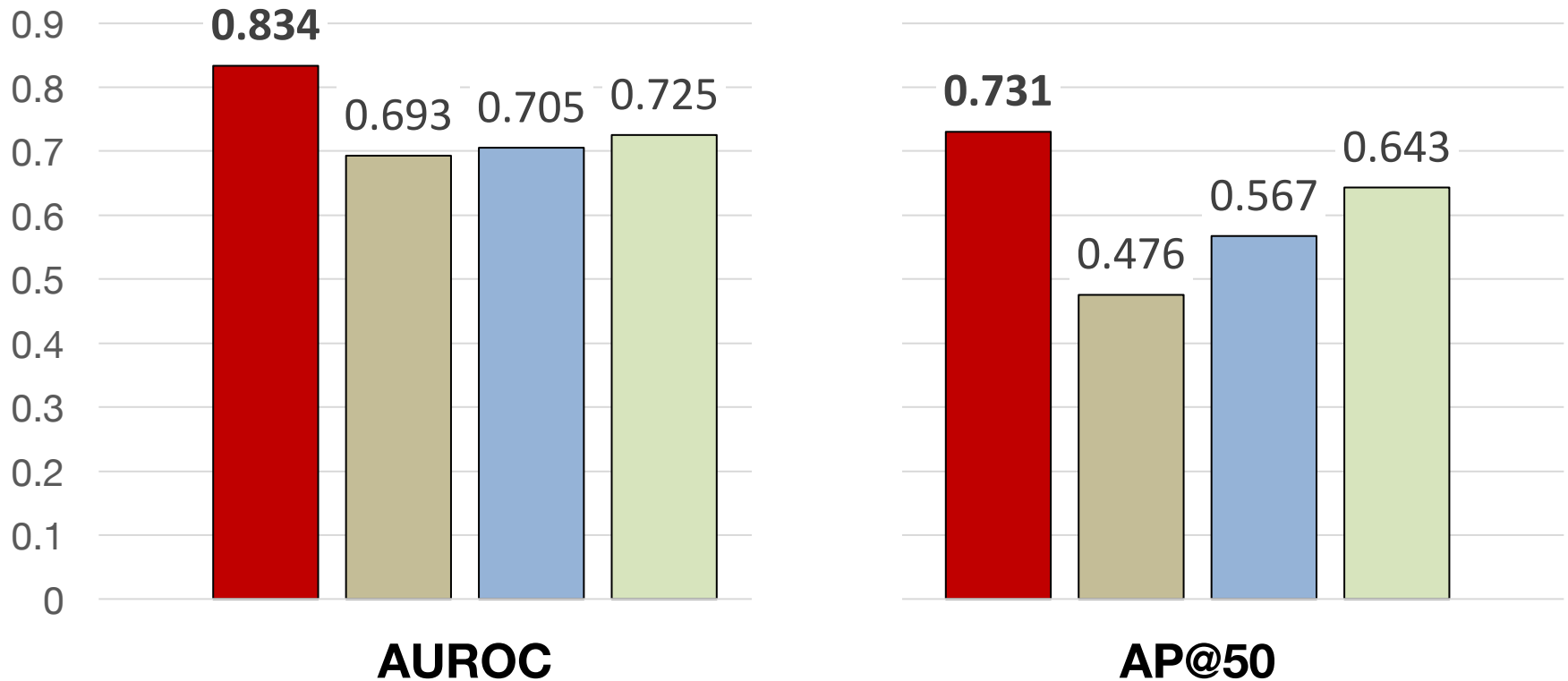

- Our method (Decagon)
- RESCAL Tensor Factorization [Nickel et al., ICML'11]
- Multi-relational Factorization [Perros, Papalexakis et al., KDD'17]
- Shallow Network Embedding [Zong et al., Bioinformatics'17]

New Predictions

First AI method to **predict side effects of drug combinations**, even for combinations not yet used in patients

Next: Can the method generate hypotheses and give:

- **Doctors** guidance on whether it is a good idea to prescribe a particular combination of drugs to a particular patient
- **Researchers** guidance on effective wet lab experiments and new drug therapies with fewer side effects

New Predictions

Approach:

- 1) Train deep model on data generated **prior to 2012**
- 2) How many **predictions** have been **confirmed after 2012**?

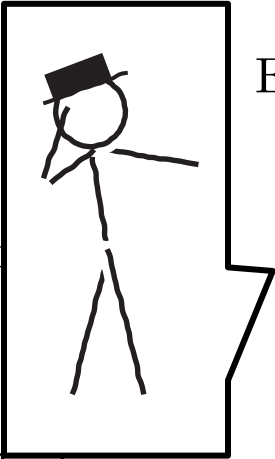
| Rank | Drug | Drug | Side effect | Evidence found |
|--|----------------|---------------|---------------------|---|
| 1 | Pyrimethamine | Aliskiren | Sarcoma |  |
| 2 | Tigecycline | Bimatoprost | Autonomic r | |
| 3 | Telangiectases | Omeprazole | Dacarbazine | |
| 4 | Tolcapone | Pyrimethamine | Blood brain | |
| <div style="border: 1px solid black; padding: 5px; margin-bottom: 5px;"> <i>Case Report</i> Severe Rhabdomyolysis due to Presumed Drug Interactions between Atorvastatin with Amlodipine and Ticagrelor </div> | | | | |
| 7 | Anagrelide | Azelaic acid | Cerebral thrombosis | headache |
| 8 | Atorvastatin | Amlodipine | Muscle inflammation | metabolic acidosis |
| 9 | Aliskiren | Tioconazole | Breast inflammation | |
| 10 | Estradiol | Nadolol | Endometriosis | |

Clinical Validation of New Predictions

Drug interaction markers, lab values, and many other surrogates



NEWTON-WELLESLEY
HOSPITAL



MASSACHUSETTS
GENERAL HOSPITAL



Stanford
MEDICINE

Robert Martin
22 Feb 1953 Male

Medication List Simple List Timeline Back to the Book Feedback Task List

show brand prn current (18) all (23)

| Medication | Brand | Dose | Frequency | Quantity | Refills | Condition | Provider | Prescribed | 2011 | 2012 | 2013 | 2014 | Renew by |
|--------------------|----------|---------|-------------|----------|---------|----------------------|----------|-------------|----------------|----------------|----------------|------|-------------|
| beclomethasone HFA | QVAR HFA | 2 puffs | bid | 12 | 12 | Asthma | Barnes | 19 Feb 2011 | [Progress bar] | | | | 19 Sep 2013 |
| chlorthalidone | | 25 mg | 1 daily | 90 | 3 | Hypertension | Barnes | 19 Sep 2006 | [Progress bar] | | | | 19 Sep 2013 |
| insulin glargine | Lantus | 28 u | daily | 90 | 11 | Diabetes | Ballard | 19 Nov 2012 | | | [Progress bar] | | 19 Sep 2013 |
| metformin | | 1000 mg | 1 bid | 180 | 3 | Diabetes | Barnes | 4 Mar 2008 | [Progress bar] | | | | 19 Sep 2013 |
| naproxen | Aleve | 500 mg | 1 bid | 90 | 0 | Rheumatoid arthritis | Barnes | 4 Mar 2008 | [Progress bar] | | | | 19 Sep 2013 |
| prednisone | | 20 mg | 2 d x5d prn | 84 | 0 | Asthma | Barnes | 12 Sep 2010 | [Progress bar] | | | | 19 Sep 2013 |
| zolpidem | | 5 mg | 1 hs | 90 | 0 | Insomnia | Barnes | 15 Mar 2012 | | [Progress bar] | | | 22 Sep 2013 |
| simvastatin | | 40 mg | 1 daily | 84 | 0 | High cholesterol | Belden | 19 Mar 2010 | [Progress bar] | | | | 30 Sep 2013 |
| terbinafine | | 250 mg | 1 daily | 84 | 0 | Onychomycosis | Foote | 30 Jul 2013 | | | | | 19 Oct 2013 |

Clinical Validation: Key Idea

Question: Is it a good idea to prescribe a particular combination of drugs to a particular patient?

- E.g., Prediction: { ,  } cause nausea as a side effect

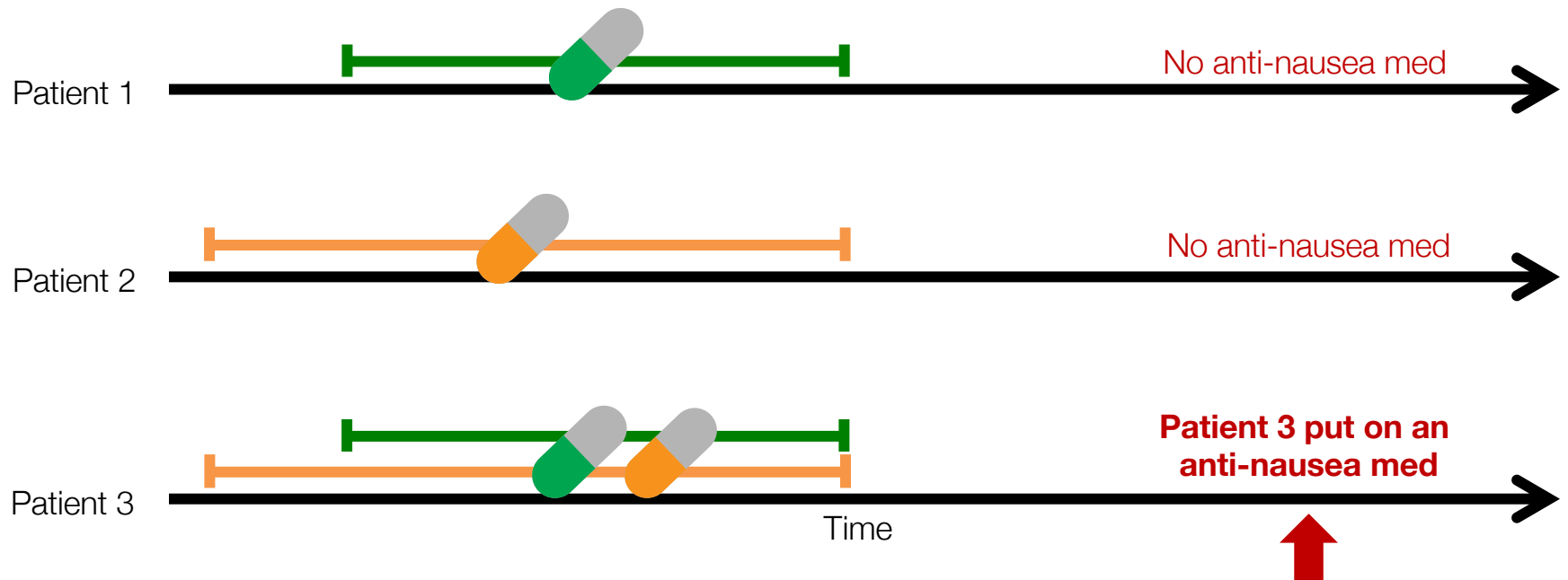

NEWTON-WELLESLEY
HOSPITAL



MASSACHUSETTS
GENERAL HOSPITAL



Stanford
MEDICINE

Today's Talk

 1. **Representation learning** for biomedical data

2. Three research applications:

 Used new approach to predict **safety** and **side effects of drug combinations**

 Used new approach to **repurpose old drugs for new diseases**

- Used new approach to **answer logical queries** on **knowledge graphs**

New tricks for old drugs

Goal: Find which diseases a drug (new molecule) could treat

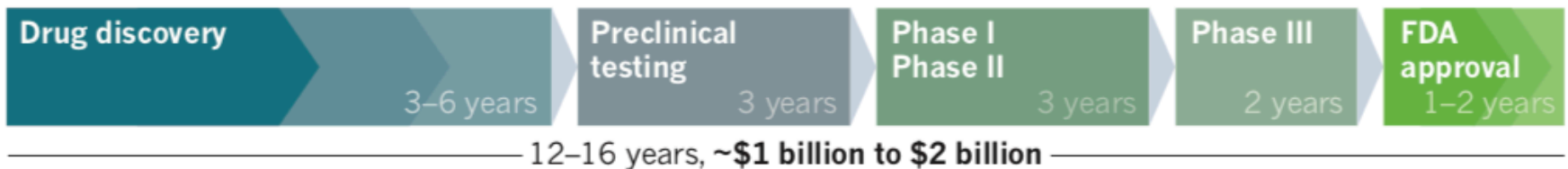

A SHORTER TIMESCALE

Because most repositioned drugs have already passed the early phases of development and clinical testing, they can potentially win approval in less than half the time and at one-quarter of the cost.

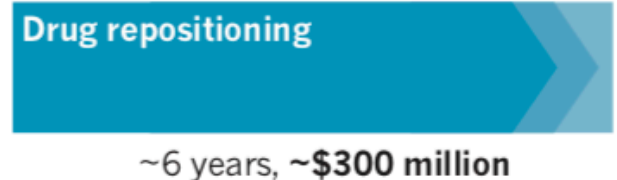

What drug treats what disease?

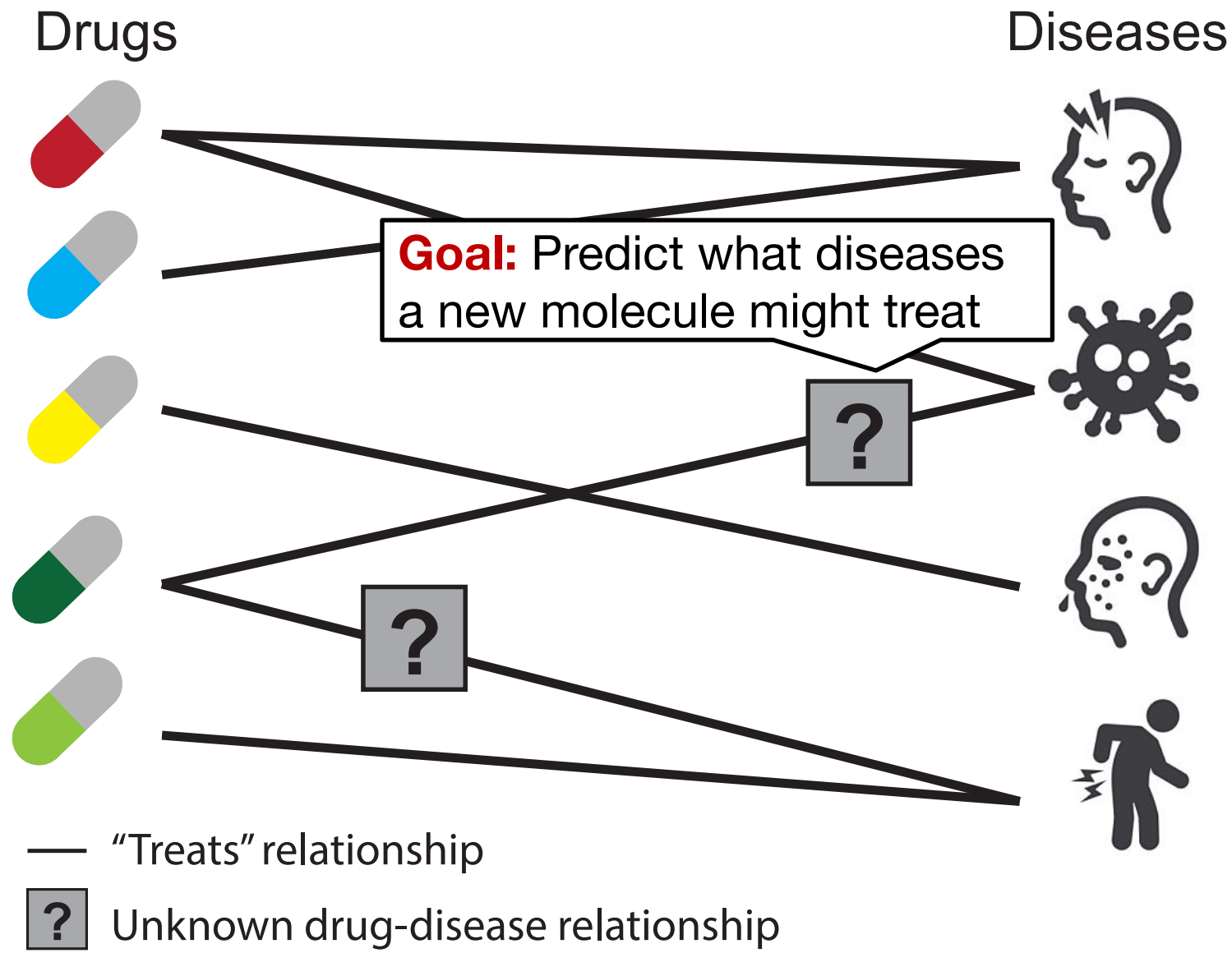

Key Insight: Subgraphs

Disease: Subgraph of rich protein network defined on disease proteins

Drug: Subgraph of rich protein network defined on drug's target proteins

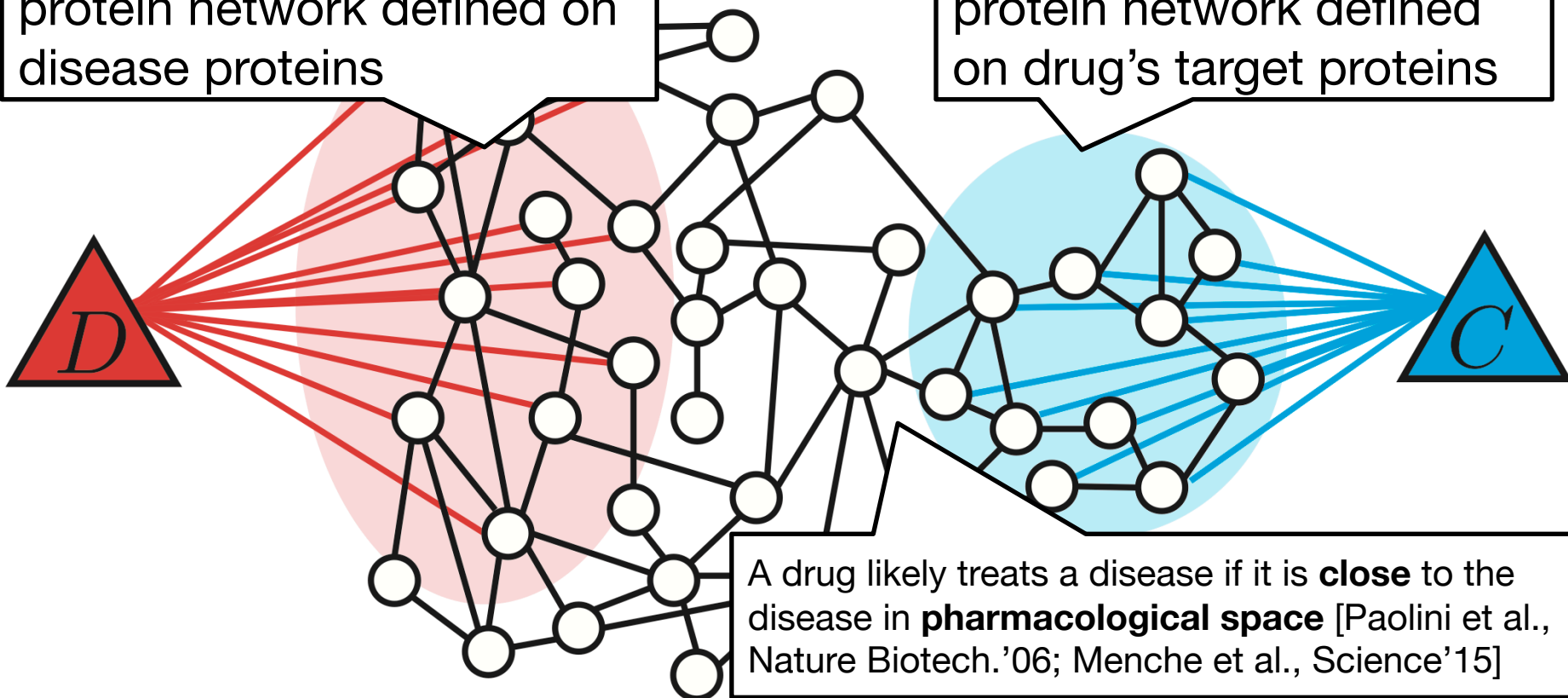

Idea: Use the paradigm of embeddings to operationalize the concept of closeness in pharmacological space

Predicting Links Between Drug and Disease Subgraphs

Task: Given drug C and disease D , predict if C treats D

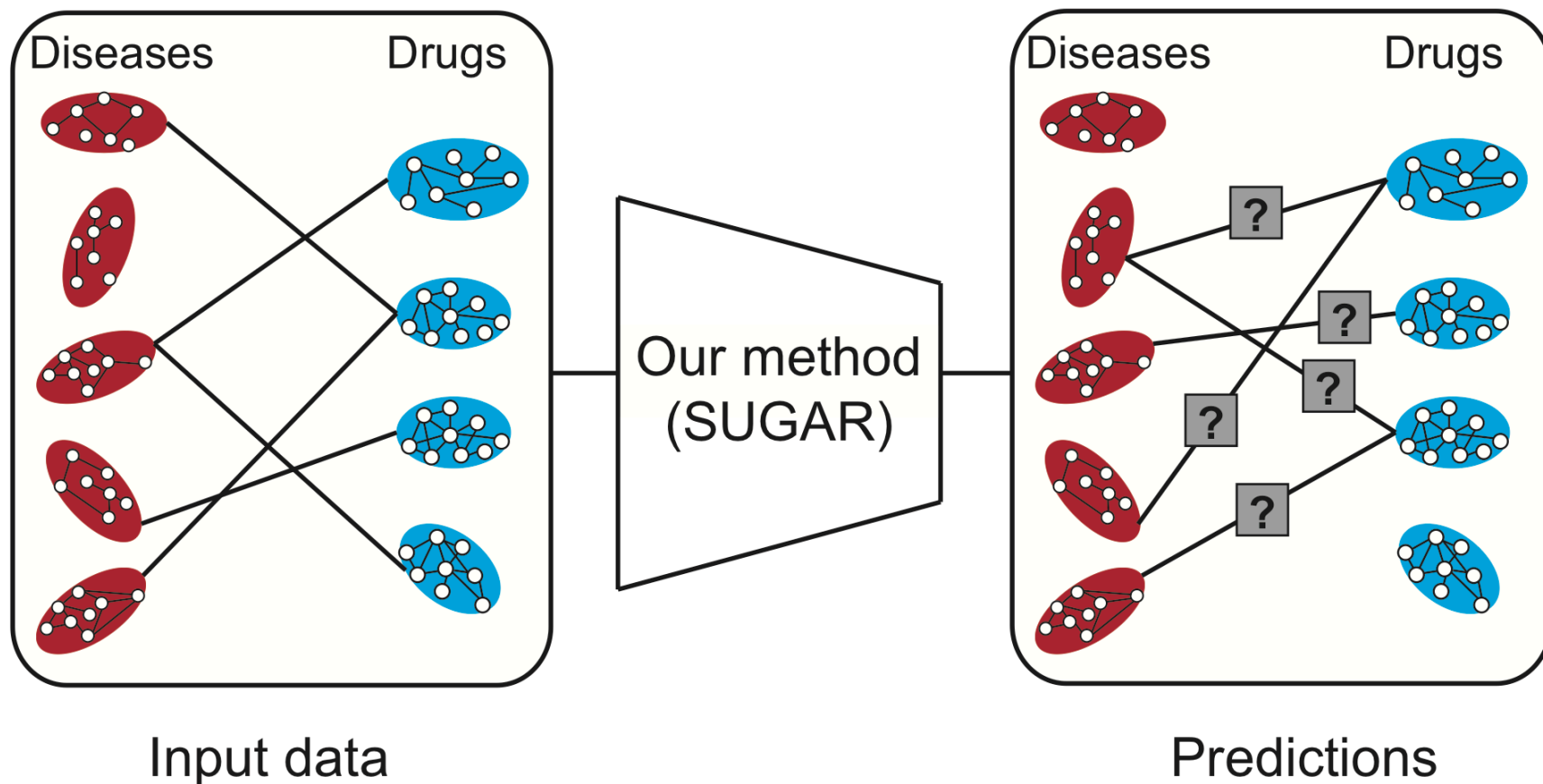

We need drug repurposing dataset

- Protein-protein interaction network culled from 15

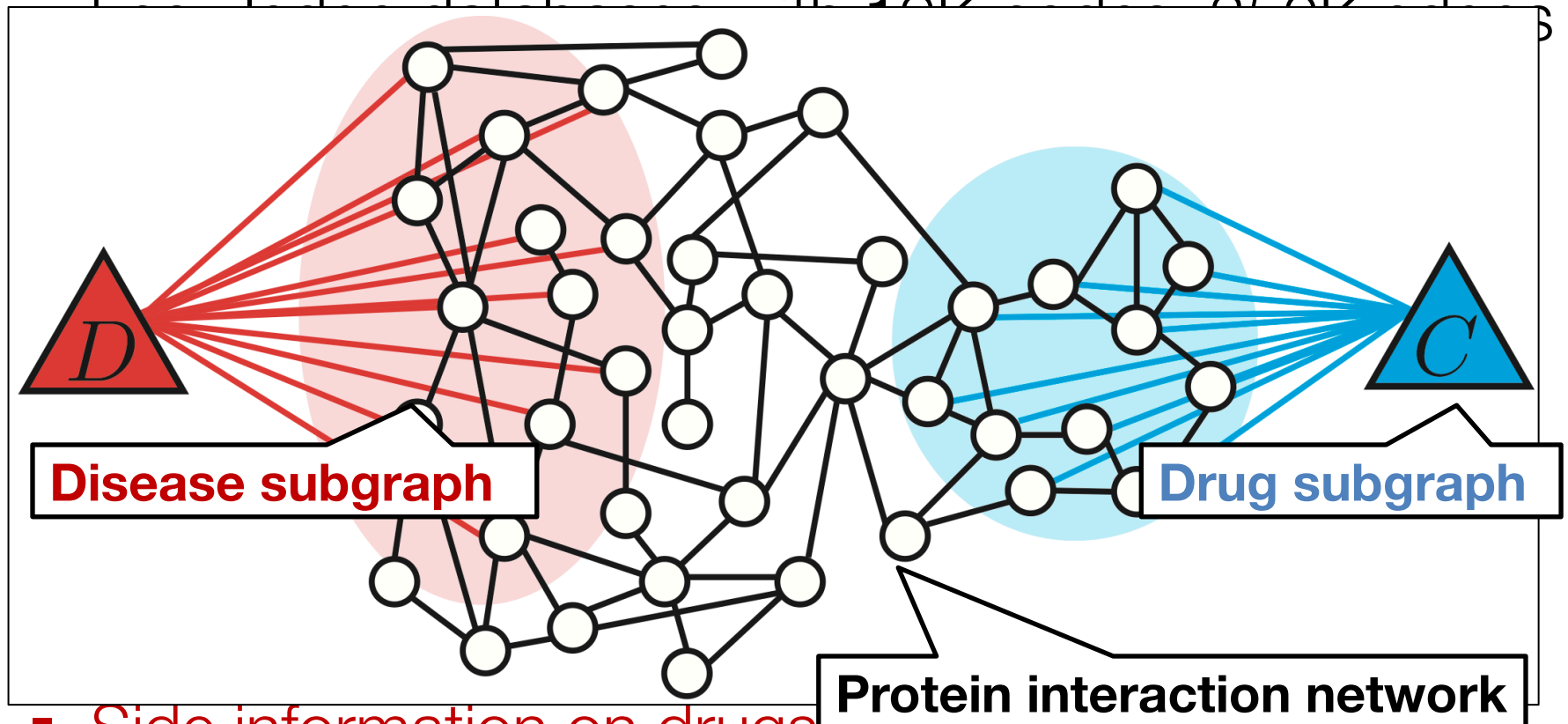

- Side information on drugs, diseases, proteins, etc..
 - Molecular pathways, disease symptoms, side effects

Predictive Performance



Task: Given a disease and a drug, predict if the drug could treat the disease

Approach

AUPRC AUROC

Our method (SUGAR)

0.851 0.888

Graphlets [Bioinformatics'13]

PREdicting Drug IndiCaTions [Mol. Sys. Biol.'11]

Bi-directional random walks [Bioinformatics'16]

Heterogeneous graph inference [Bioinformatics'14]

Drug-disease closeness [Nat. Commun.'17]

Drug-disease dispersion [Nat. Commun.'17]

Gene-based network overlap [Nat. Commun.'17]

**Up to 49%
improvement**

**Up to 172%
improvement**

Feedbacks for the AI Loop

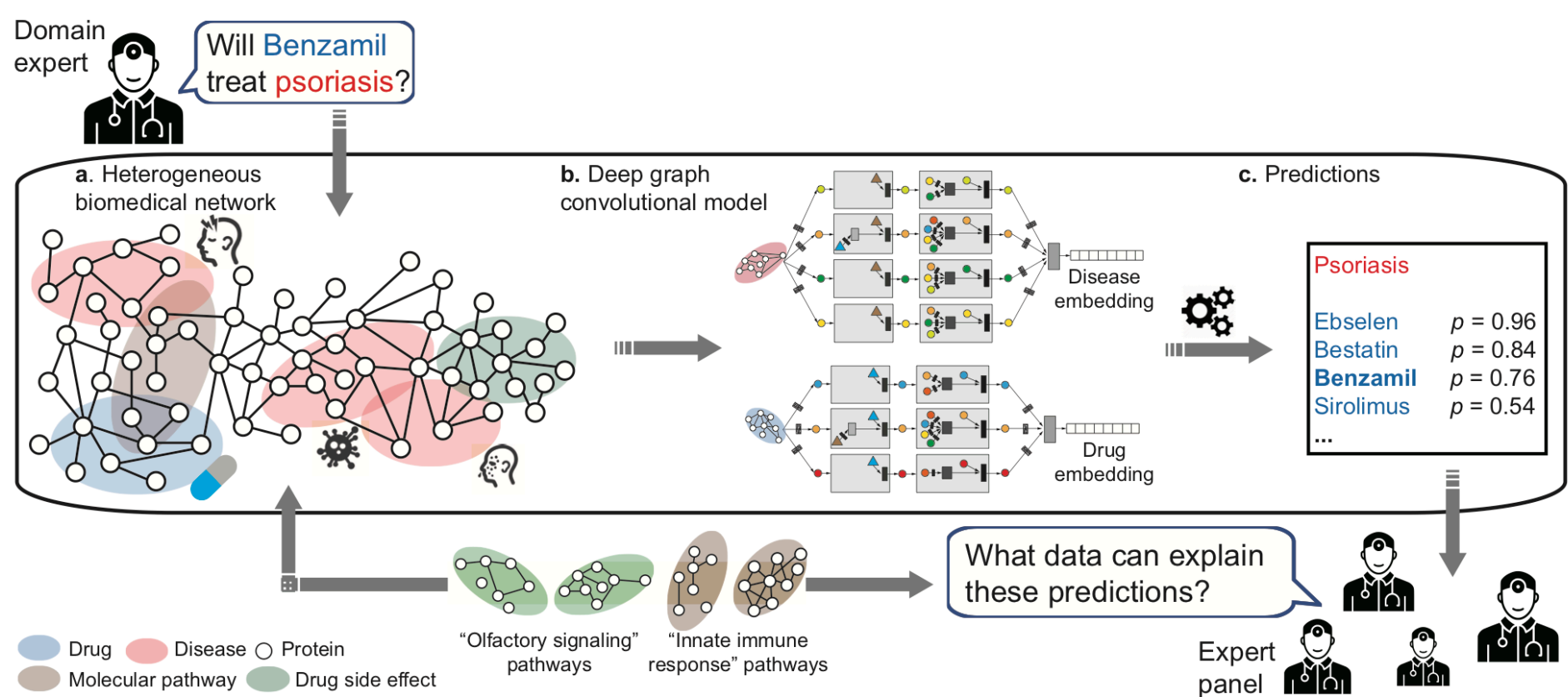

Feedbacks for the AI Loop

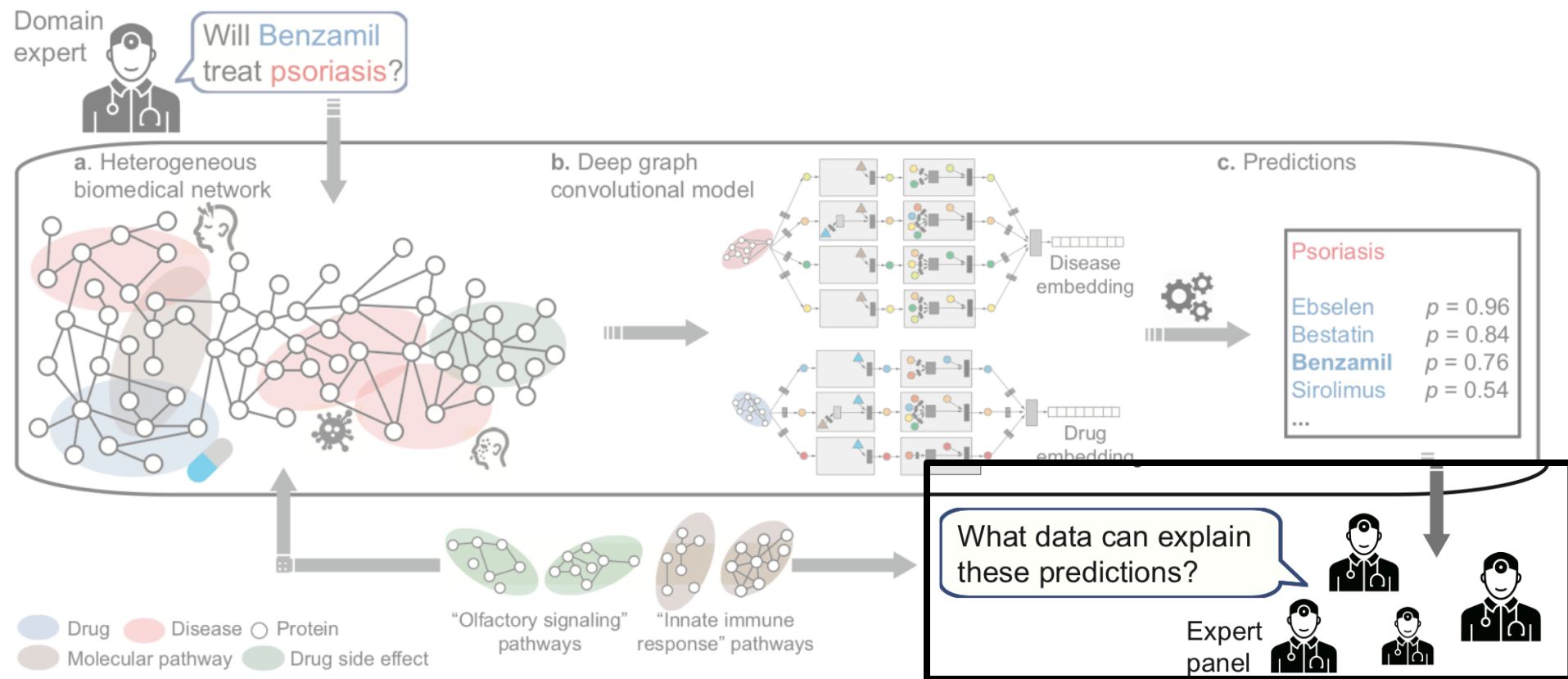

Explaining Machine Predictions

Key idea:

- Summarize where in the data the model “looks” for evidence for its prediction
- Find a small subgraph most influential for the prediction



GNN model training and predictions

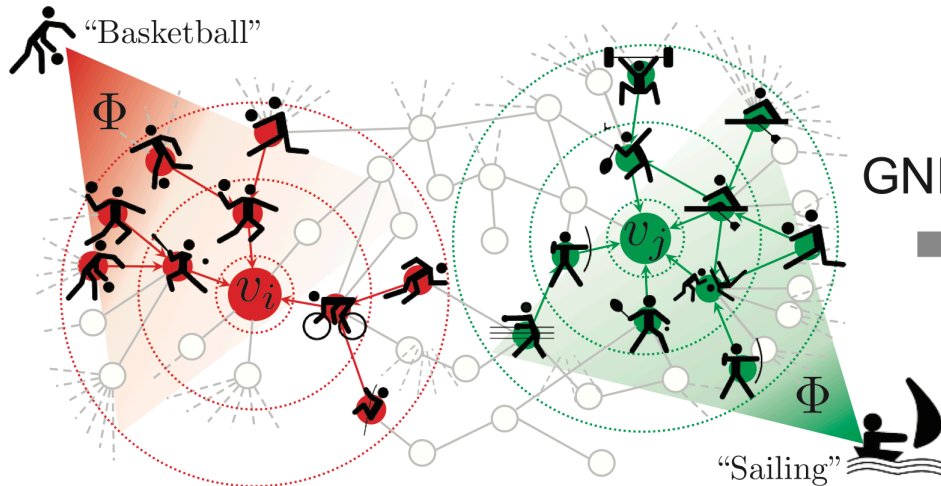

Explaining GNN's predictions

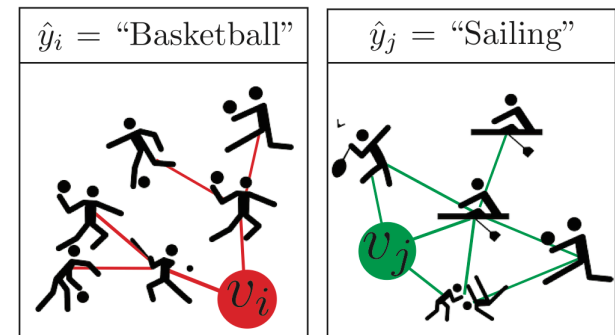

Approach to generate explanations using **counterfactual reasoning**

GNNExplainer: Key Idea

- **Input:** Given prediction $f(x)$ for node/link x
- **Output:** Explanation, a small subgraph M_x together with a small subset of node features:
 - M_x is most influential for prediction $f(x)$
- **Approach:** Learn M_x via counterfactual reasoning
 - **Intuition:** If removing v from the graph strongly decreases the probability of prediction $\Rightarrow v$ is a good counterfactual explanation for the prediction

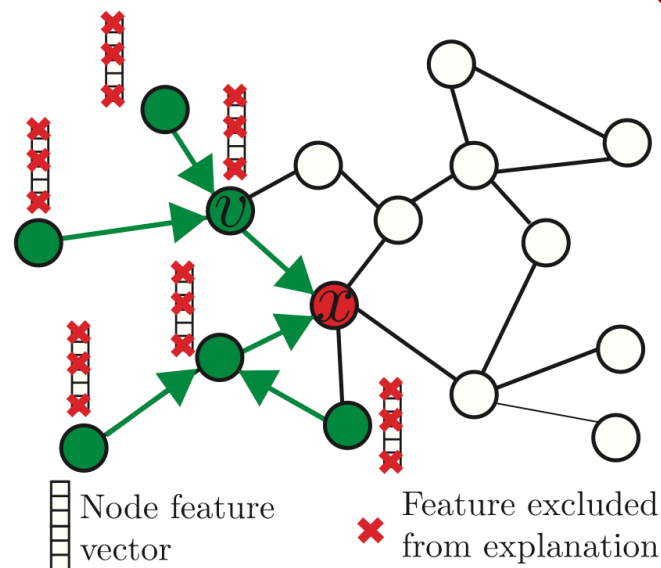

GNNExplainer: Results

"Why did you predict that this molecule will have a mutagenic effect on Gram-negative bacterium *S. typhimurium*?"



Explanation

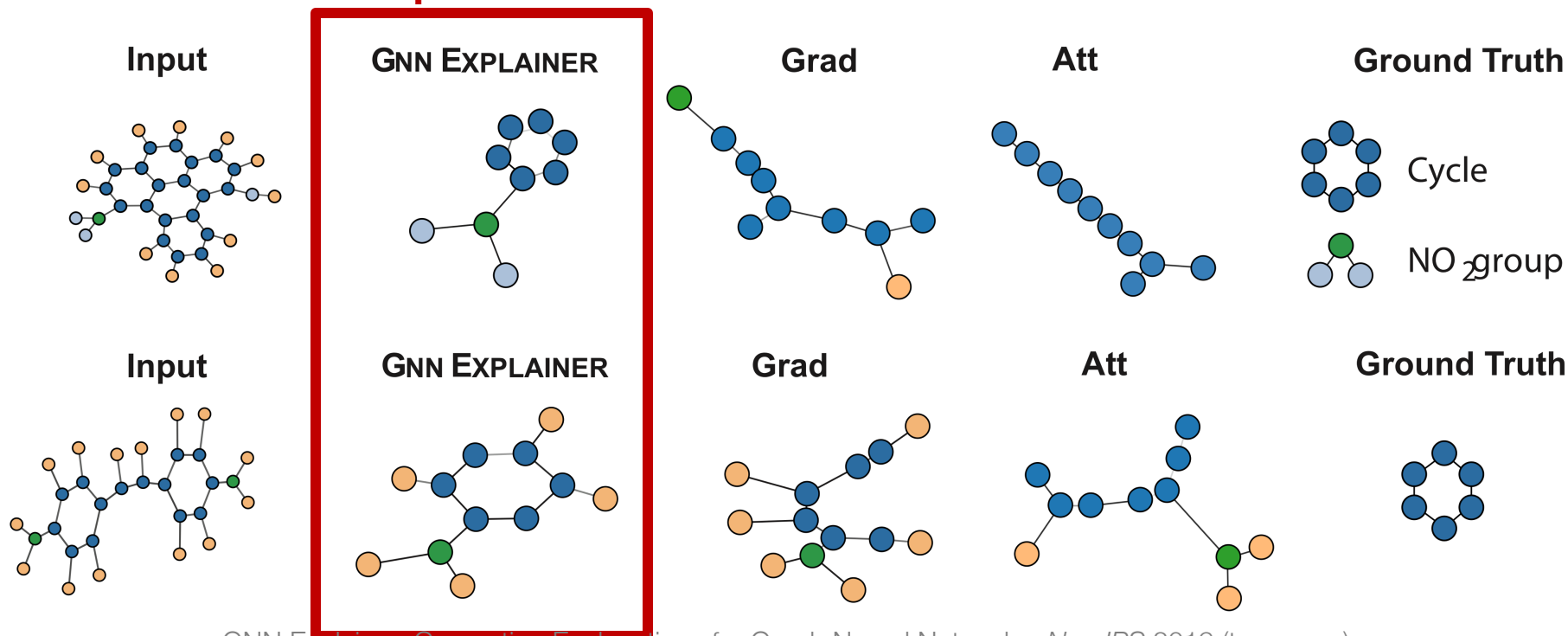

Today's Talk

 1. **Representation learning** for biomedical data

2. Three research applications:

 Used new approach to predict **safety** and **side effects of drug combinations**

 Used new approach to **repurpose old drugs for new diseases**

 Used new approach to **answer logical queries** on **knowledge graphs**

Knowledge Graphs

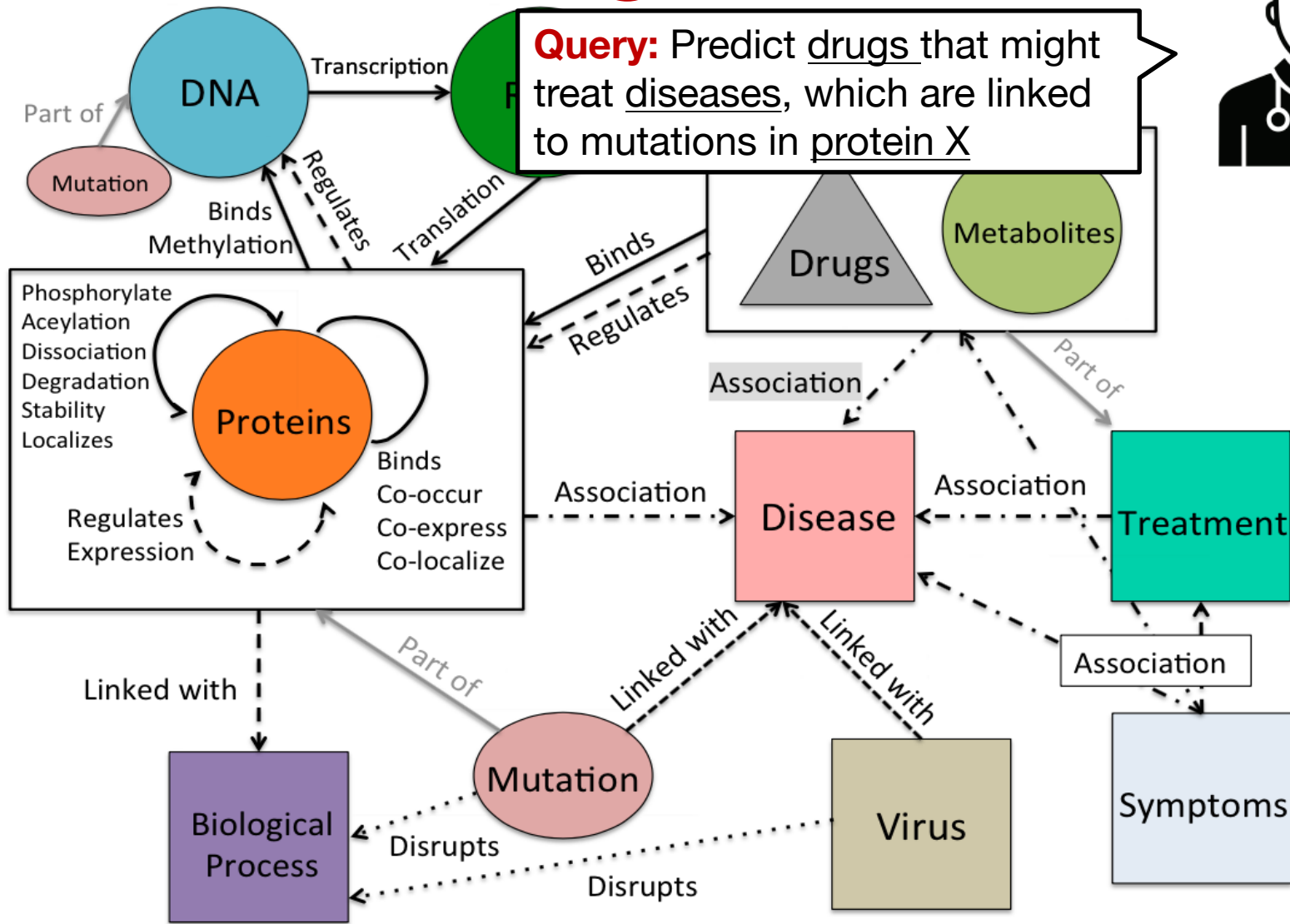

Learn over Knowledge Graphs

Simple edge prediction

Predict drugs $C_?$ that treat disease d

$$C_? : \text{TREAT}(C_?, d)$$

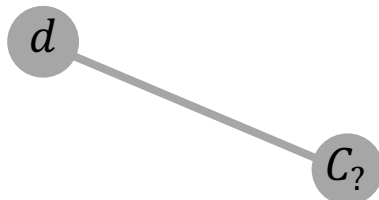

Answering logical queries

Predict drugs $C_?$ that might TARGET proteins, which are in turn ASSOCIATED with diseases d_1 and d_2

$$C_?.\exists P : \text{ASSOC}(d_1, P) \wedge \text{ASSOC}(d_2, P) \wedge \text{TARGET}(P, C_?)$$

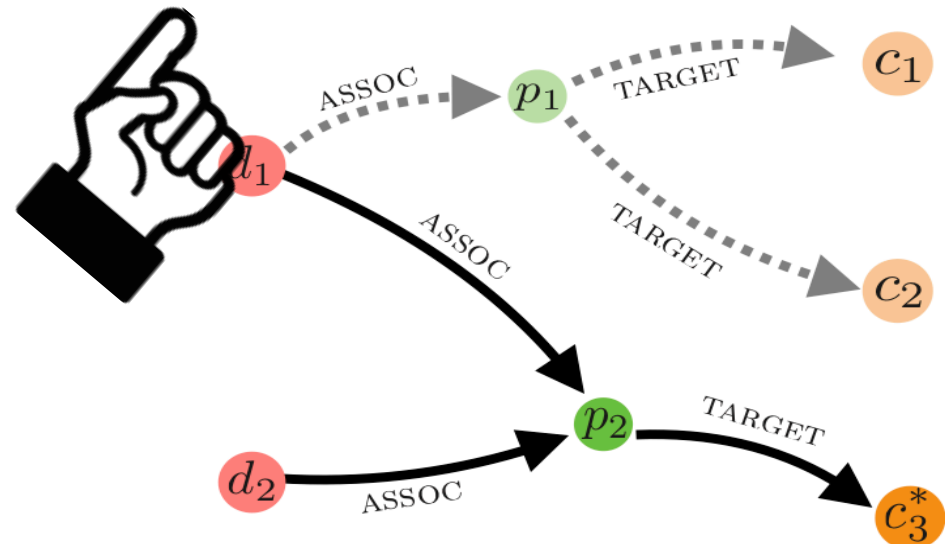
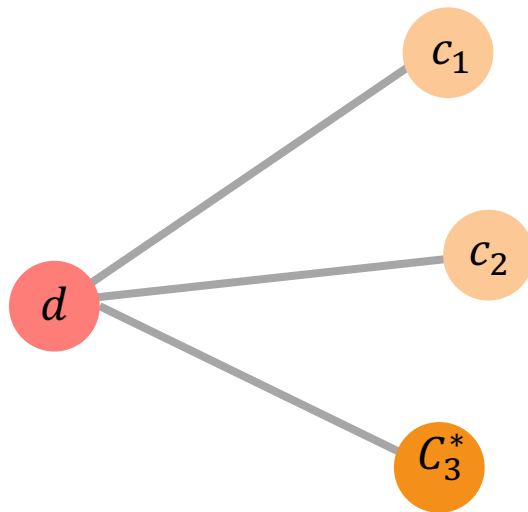
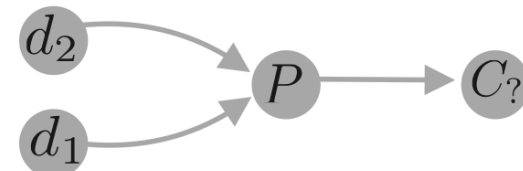

Why is query prediction on knowledge graphs a hard problem?

1) Massive enumerations

- E.g., the protein node is an existentially quantified variable
- Need to enumerate over all possible protein nodes

1) Exponential computations

- Combinatorial number of possible answers to the query
- Naive enumeration approach has exponential time complexity in the number of query variables

Logical query

Predict drugs $C_?$ that might TARGET proteins, which are in turn ASSOCIATED with diseases d_1 and d_2

$$C_?.\exists P : \text{ASSOC}(d_1, P) \wedge \text{ASSOC}(d_2, P) \wedge \text{TARGET}(P, C_?)$$

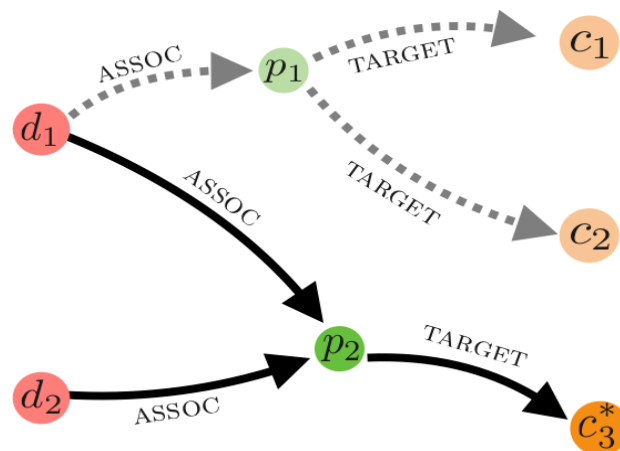
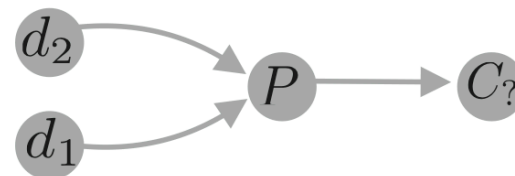

Approach: Query Embeddings

Two key steps:

- 1) Generate an embedding for every node in the graph
- 2) Represent **logical operators** as **learned geometric operations** (e.g., translation, rotation) in this embedding space

- **Any conjunctive query:** Can predict which nodes are likely to satisfy any query, even if it involves unobserved edges
- **Efficient:** Linear time complexity in size of the query and constant in size of the knowledge graph

$C_?.\exists P : \text{TARGET}(C_?, P) \wedge \text{ASSOC}(P, d_2) \wedge \text{ASSOC}(P, d_2)$

Input query

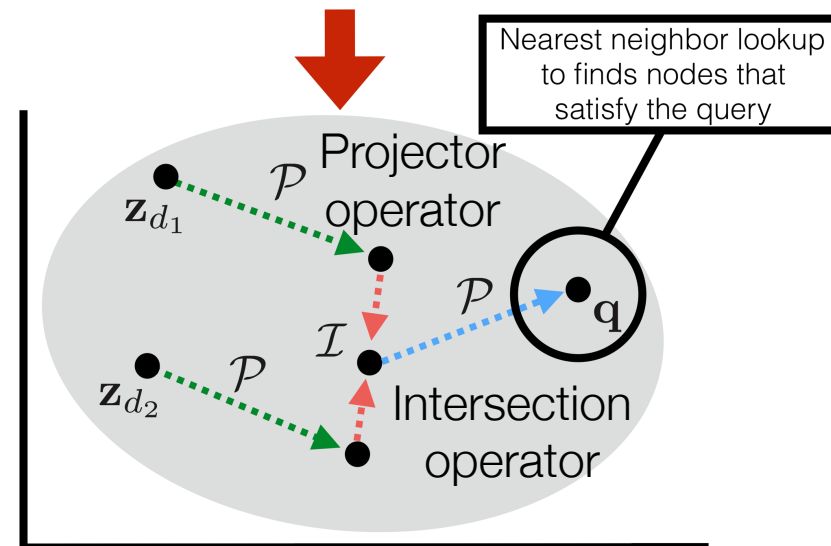
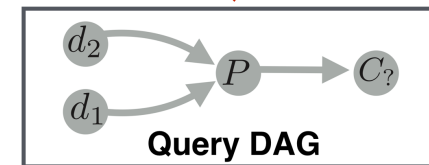

Operations in an embedding space

Query Embeddings: Results

Data: Biomedical knowledge graph

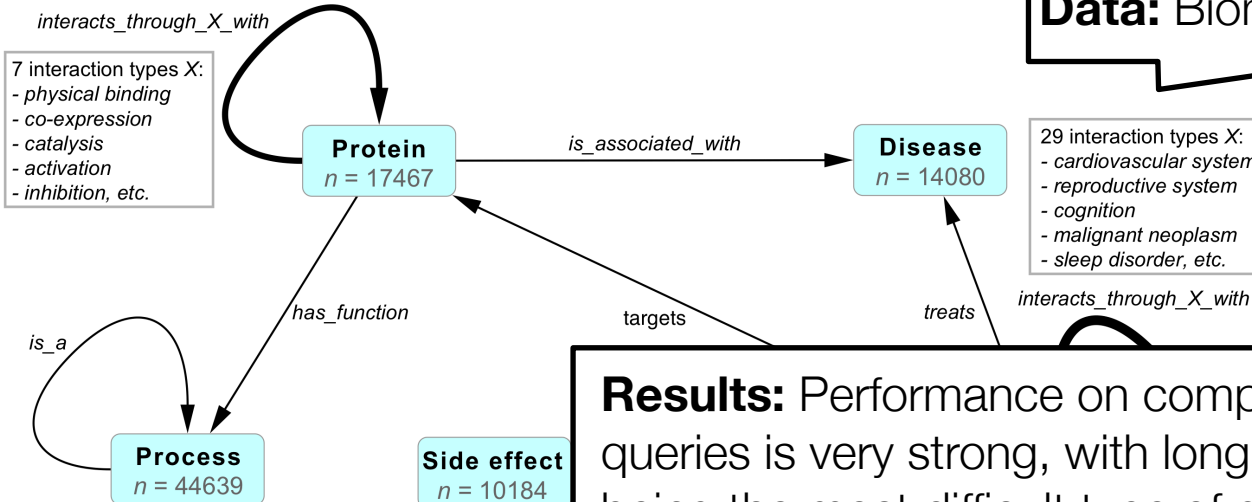

Results: Performance on complex queries is very strong, with long paths being the most difficult type of query

Results: Ablated models that are only trained on edge prediction perform much worse than query embeddings

Summary of Results

1. Used new approach to **predict safety and side effects of drug combinations:**
 - First-ever systematic and predictive study of **drug combinations**
 - **Follow-up research** on prostate cancer and validations in the clinic
2. Used new approach to **repurpose old drugs for new diseases:**
 - Outperforms baselines by up to 172%
 - **Correctly predicted drugs repurposed** at Stanford SPARK
3. Used new approach to **answer logical queries on knowledge graphs:**
 - *Predict drugs that might treat diseases linked to mutations in protein X*
 - Ability to answer logical queries in **a linear** instead of exponential time

Large datasets are transforming science and medicine

New machine learning methods can unlock these datasets and open doors for scientific discoveries

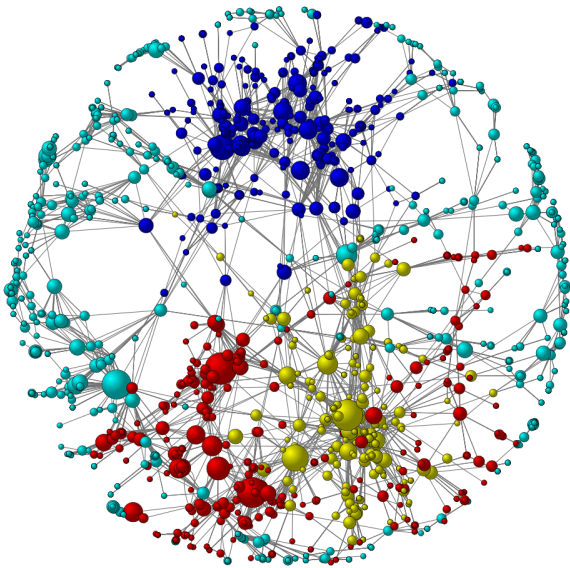

Data



Data + ML/AI



Predictions
and insights

Thank you!

Papers, tutorials, data & code
ai.stanford.edu/~marinka



HARVARD
UNIVERSITY

**WE'RE
HIRING!**

I am hiring outstanding postdocs for projects in machine learning and biomedical data!